

Synchronous machine

1. Construction

Synchronous Machines

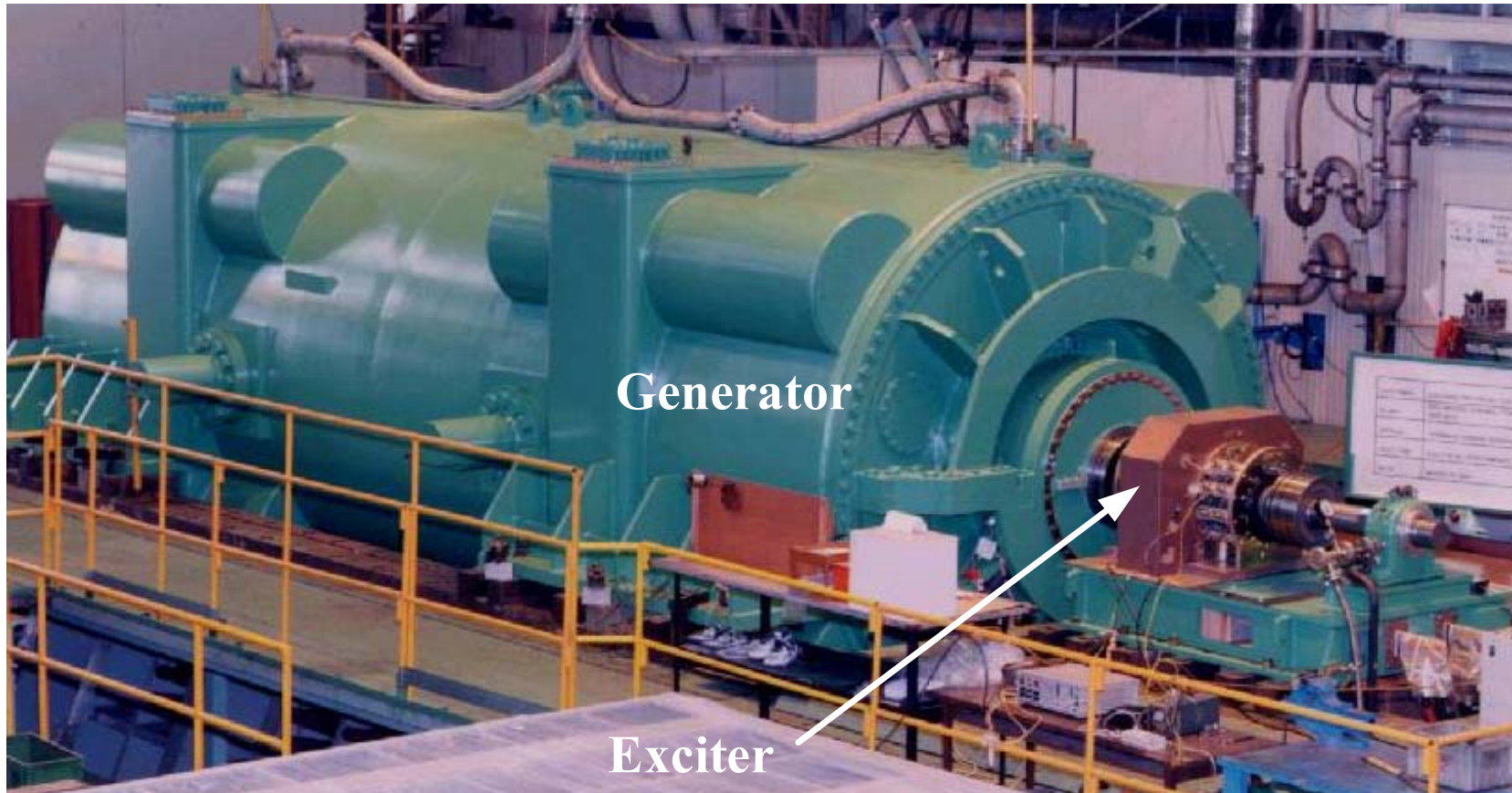

View of a two-pole round rotor generator and exciter.

Synchronous Machines

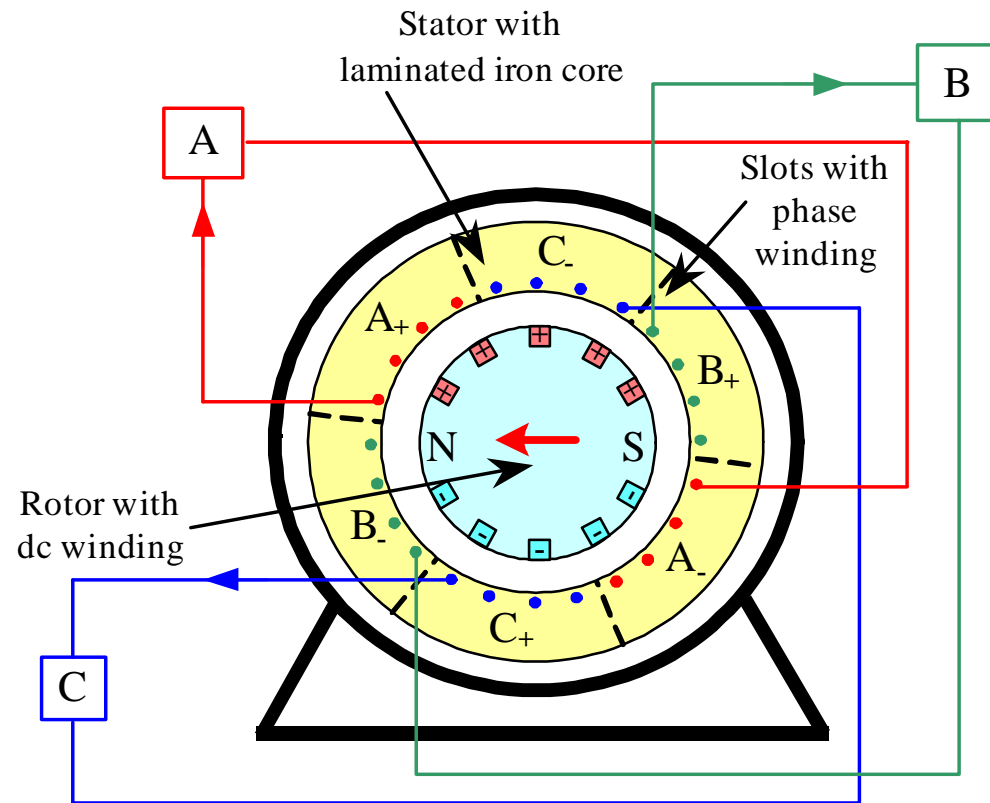

Major components of a round rotor two-pole generator

Synchronous Machines

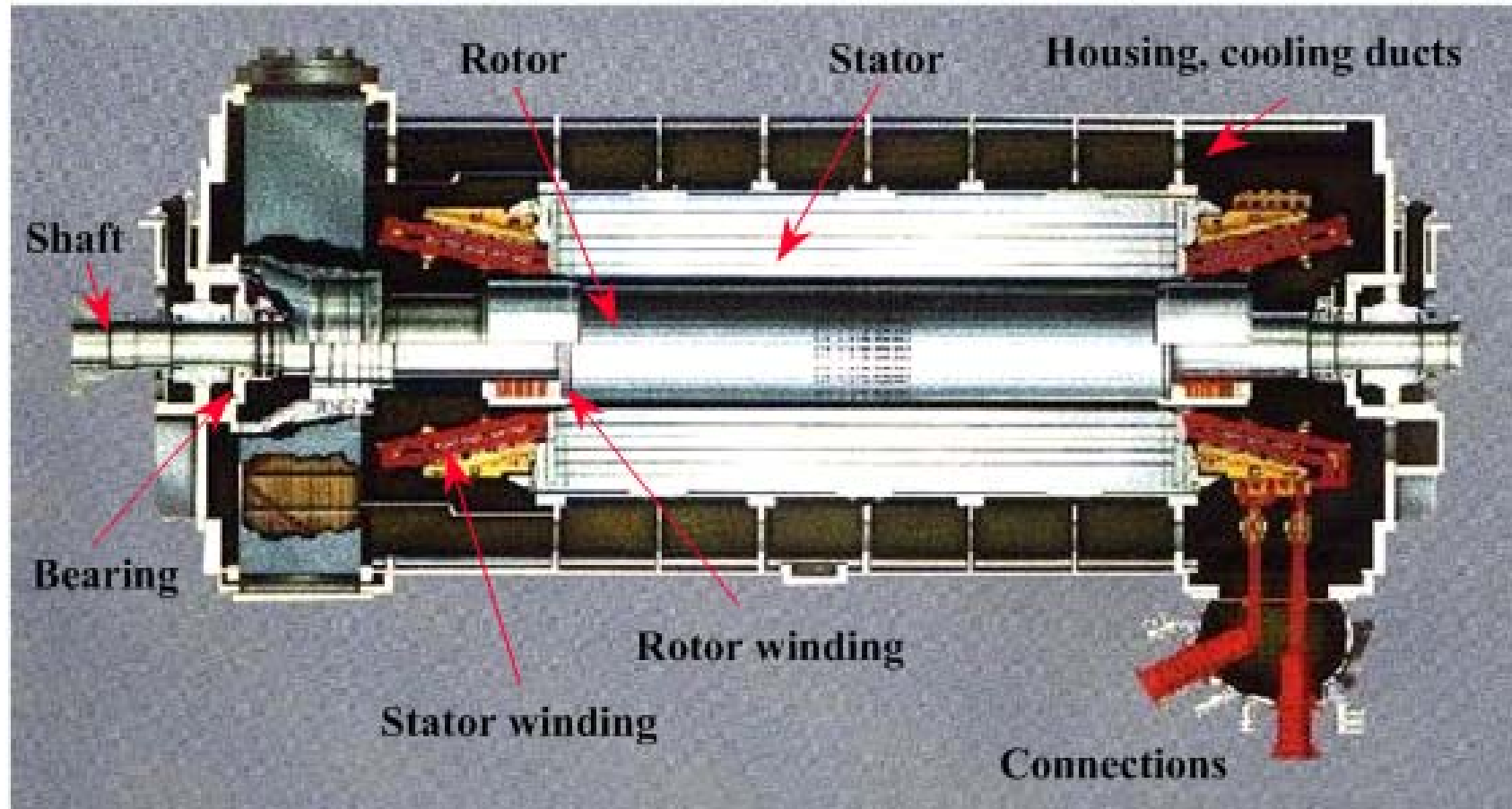

Cross-section of a large turbo generator. (Courtesy Westinghouse)

Synchronous Machines

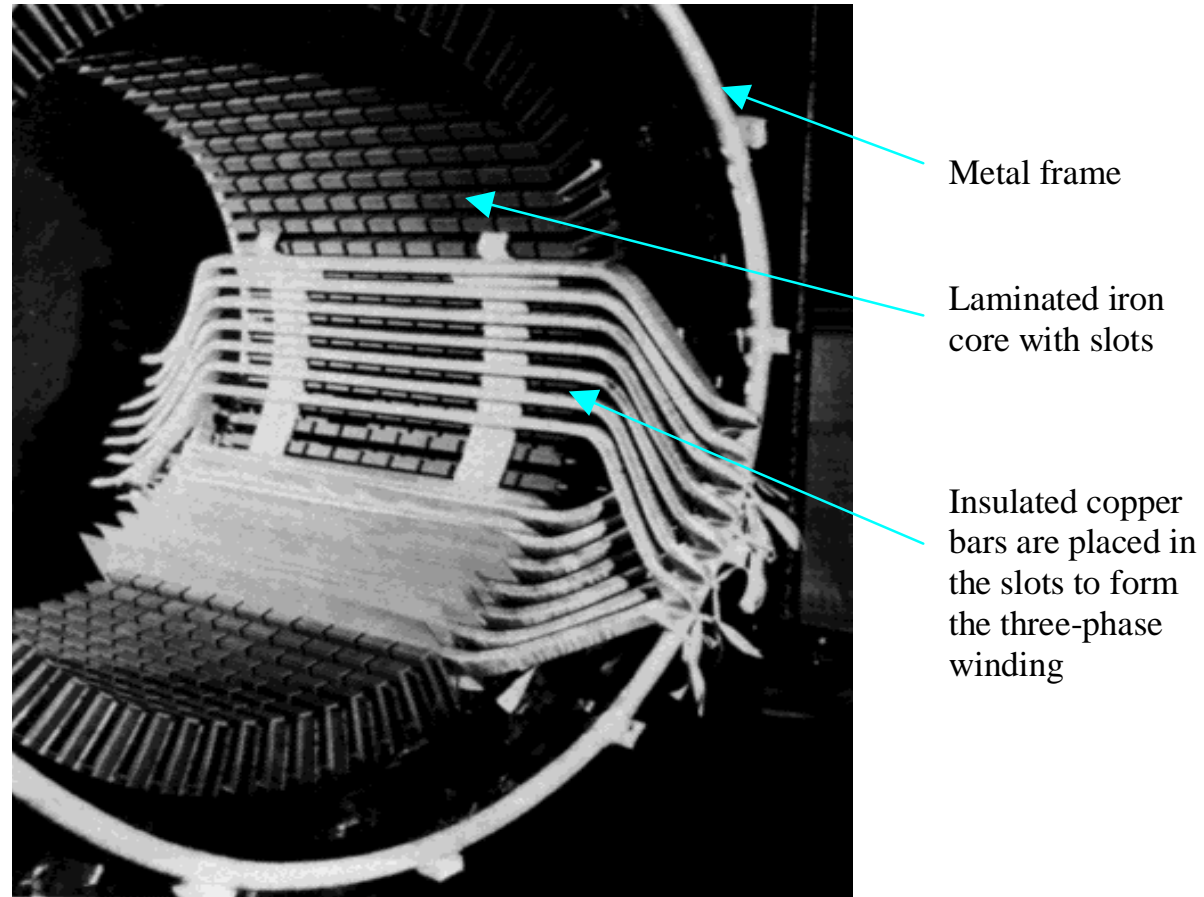

Details of a generator stator.

Synchronous Machines

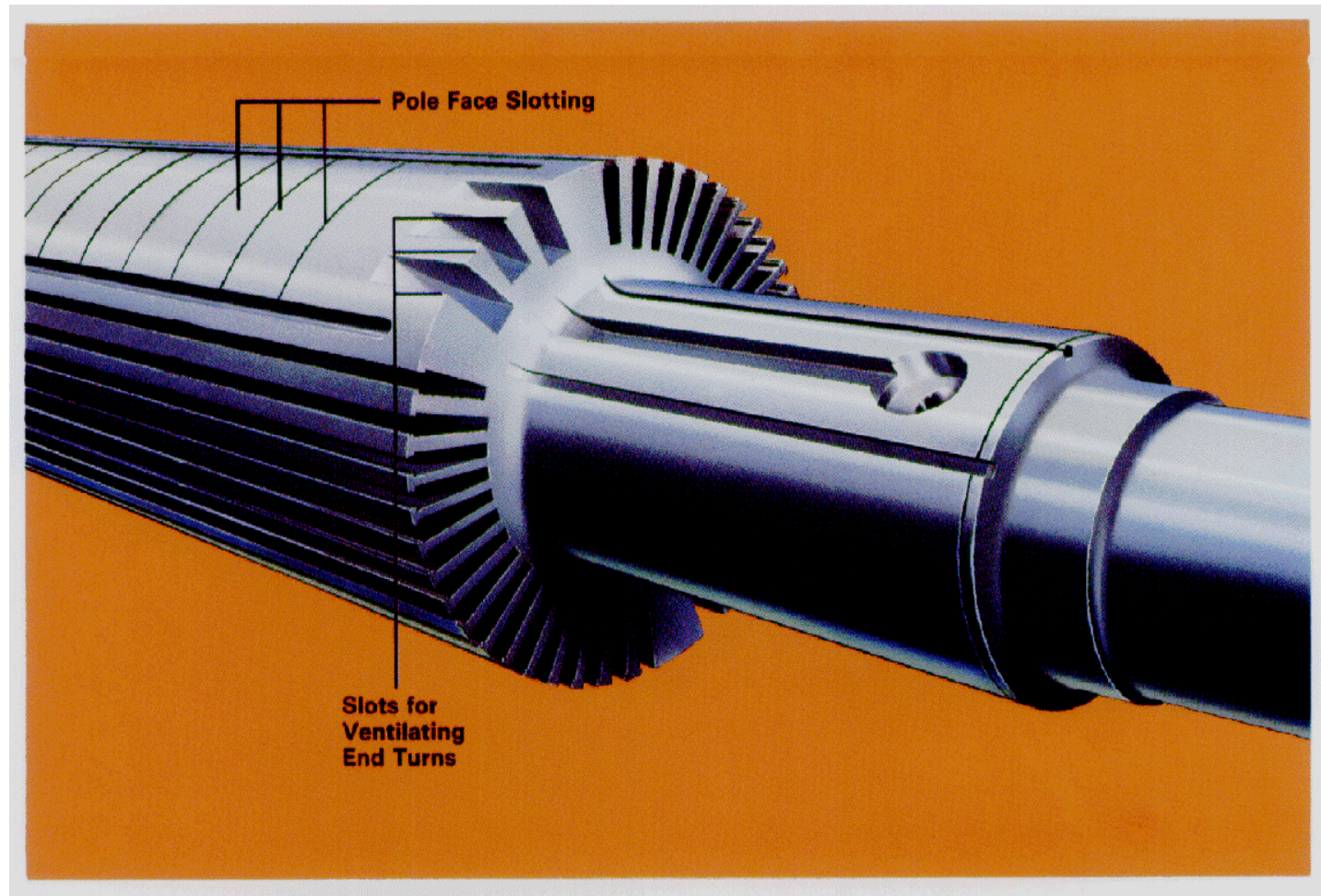

Rotor block of a large generator. (Courtesy Westinghouse)

Synchronous Machines

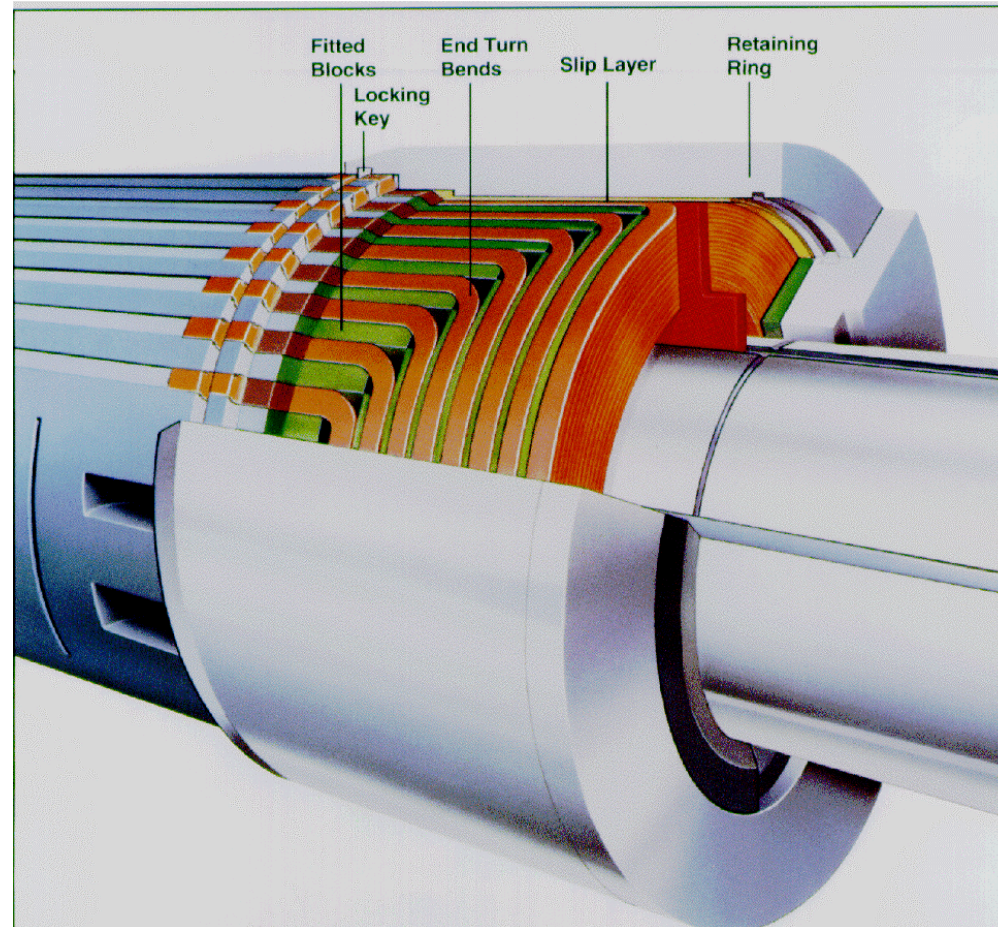

Generator rotor with conductors placed in the slots.

Synchronous Machines

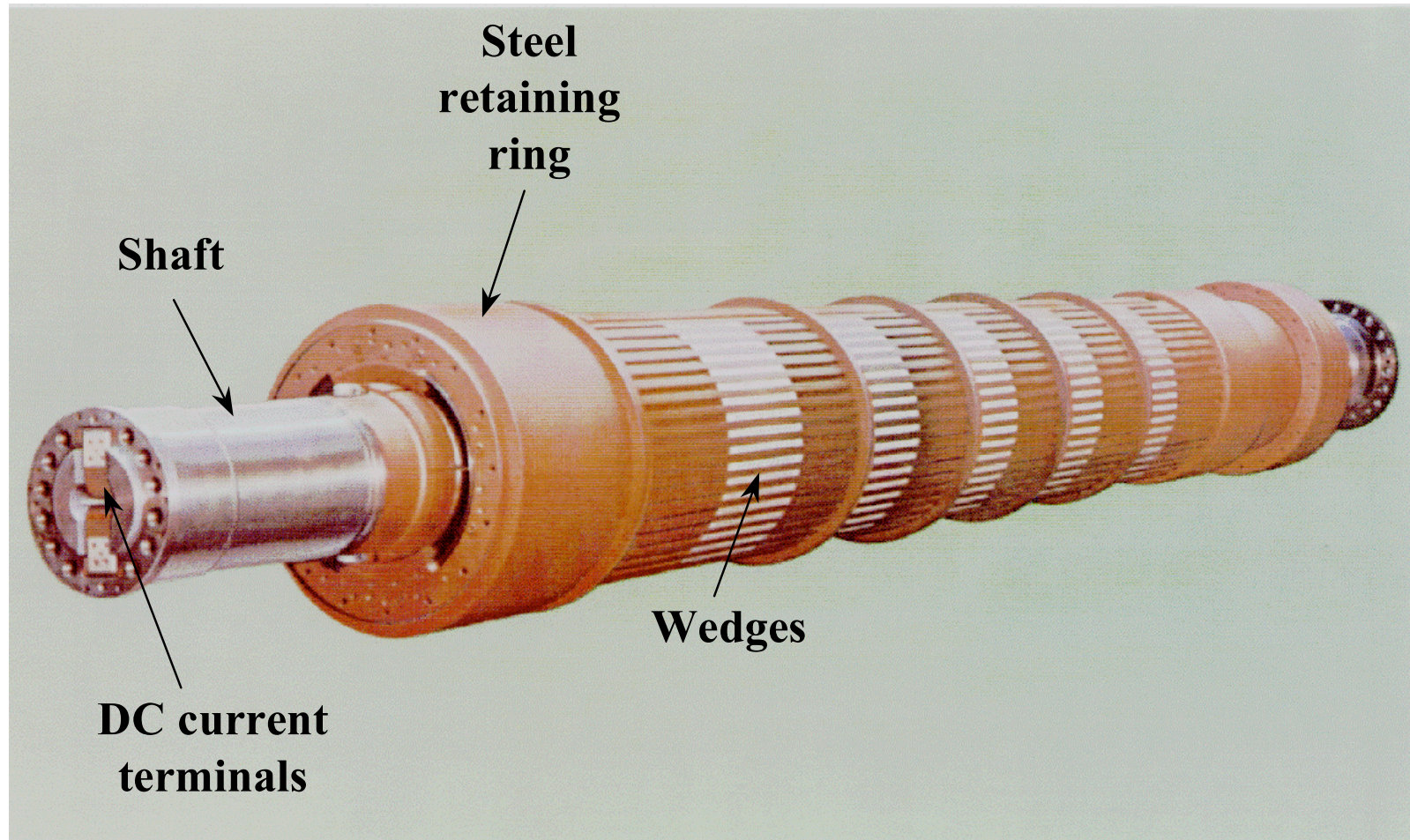

Large generator rotor completely assembled. (Courtesy Westinghouse)

Synchronous Machines

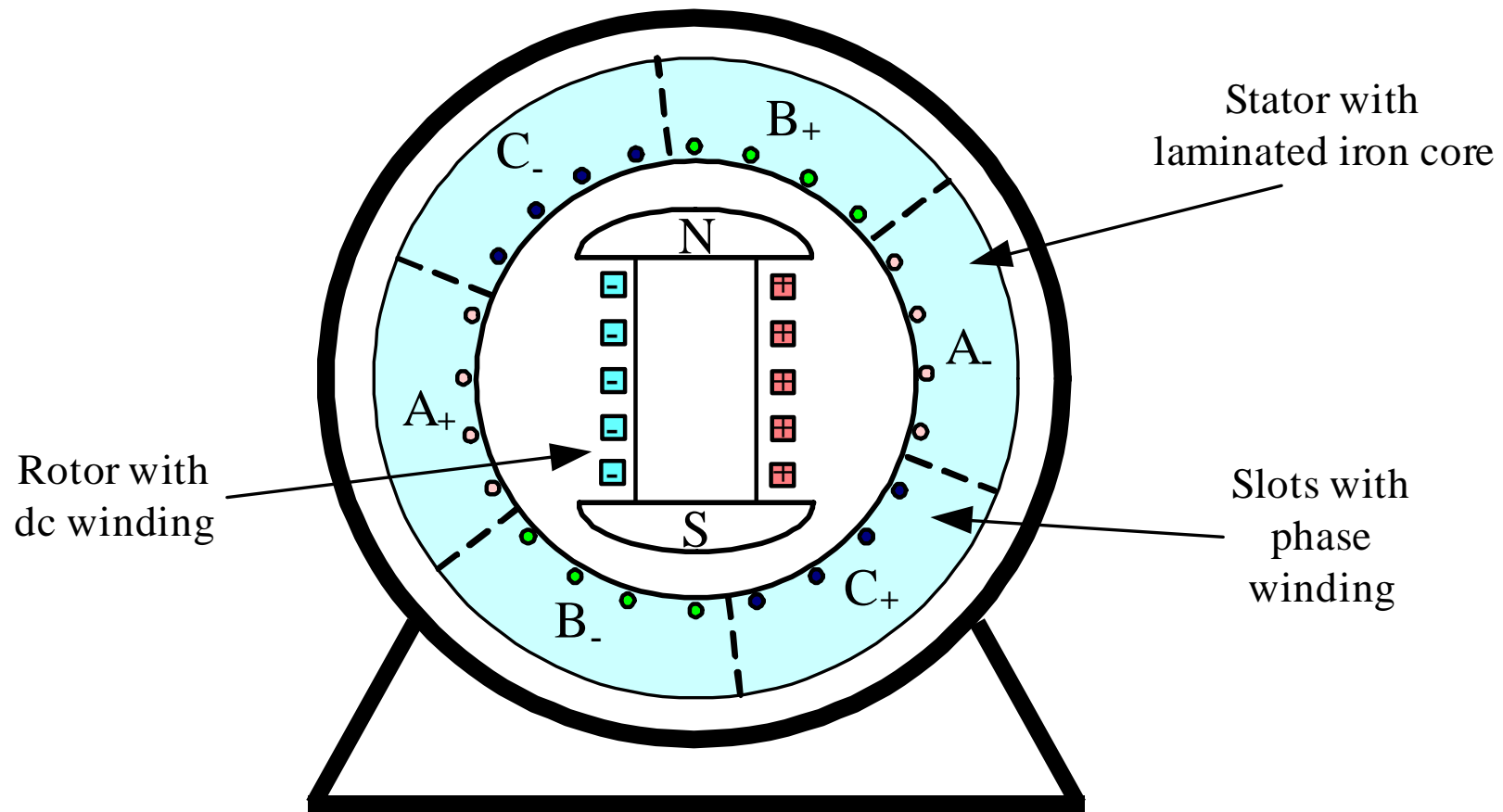

Two-pole salient pole generator concept.

Synchronous Machines

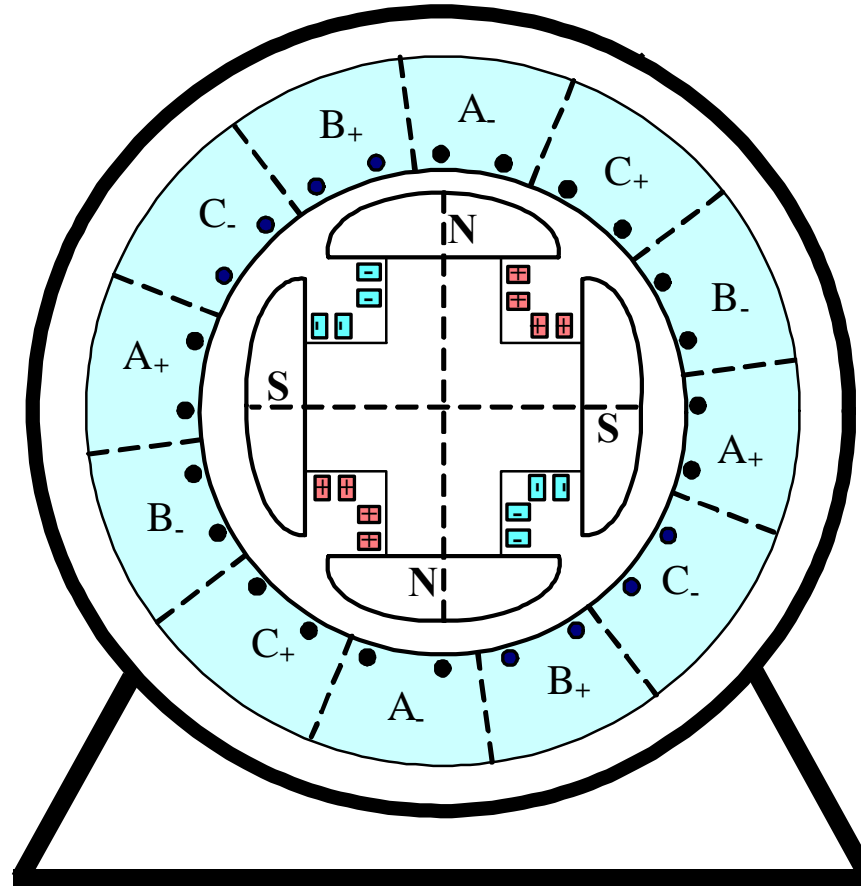

Four-pole salient pole generator concept.

Synchronous Machines

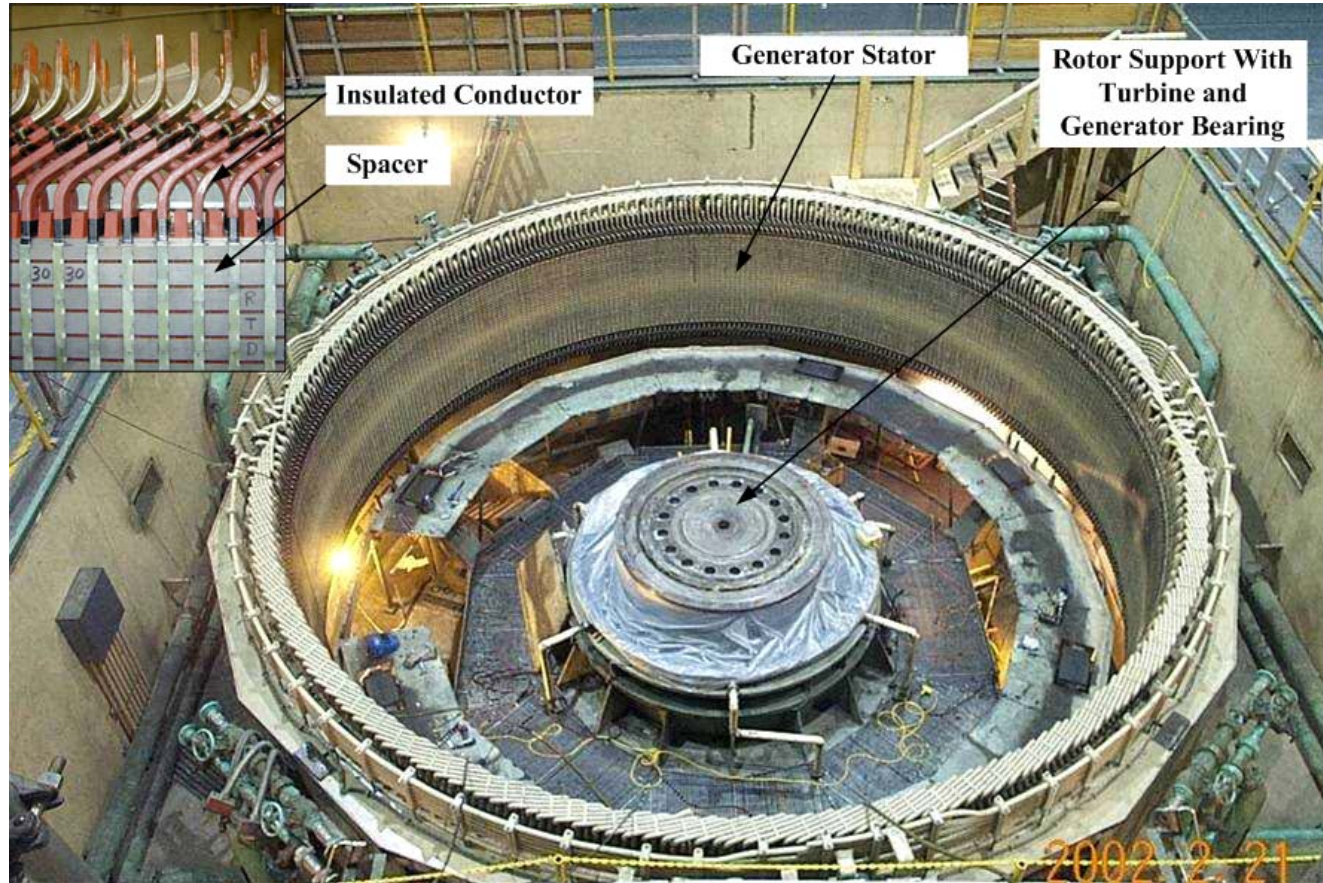

Stator of a large salient pole hydro generator; inset shows the insulated conductors and spacers.

Synchronous Machines

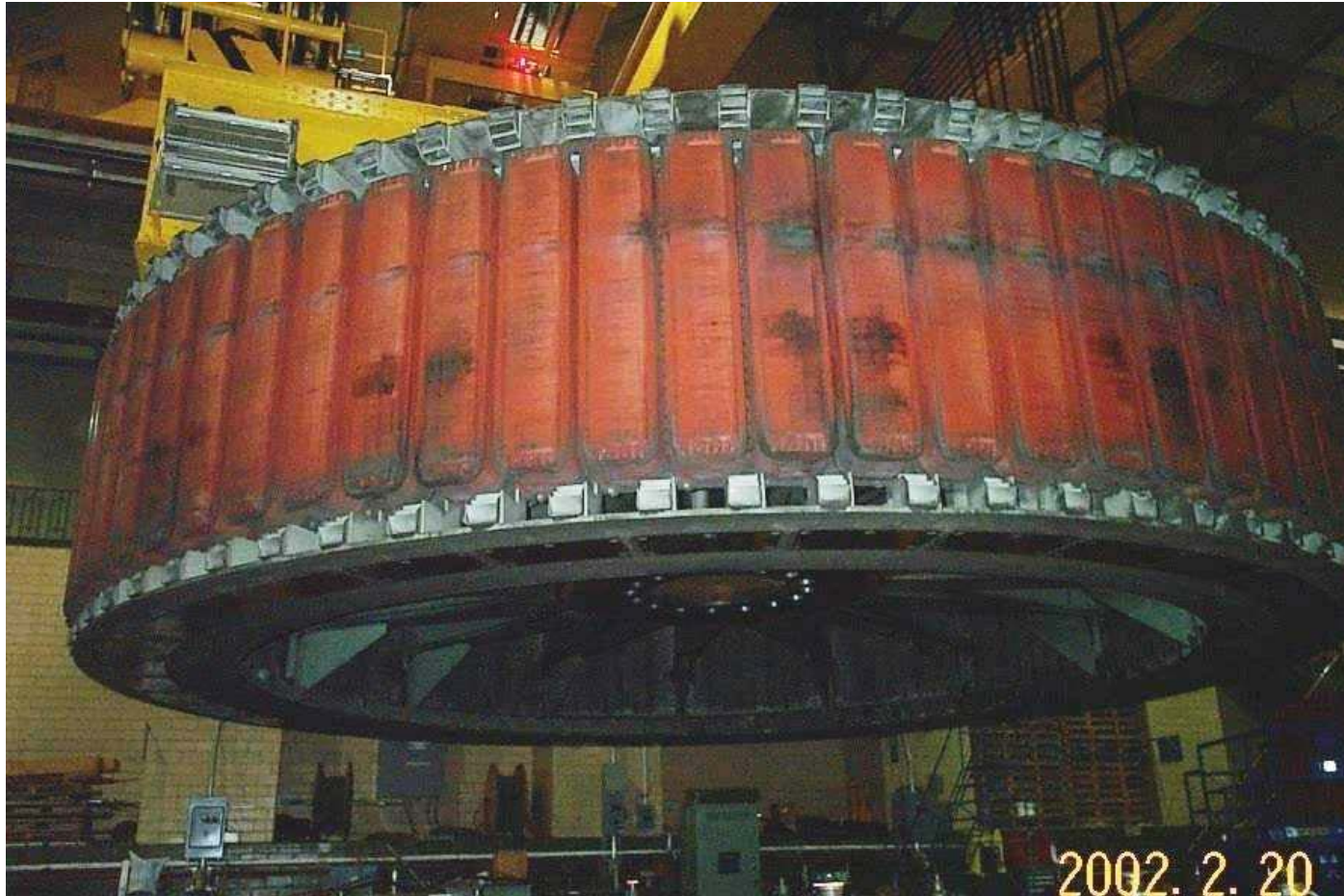

Large hydro generator rotor with view of the vertical poles.

Synchronous Machines

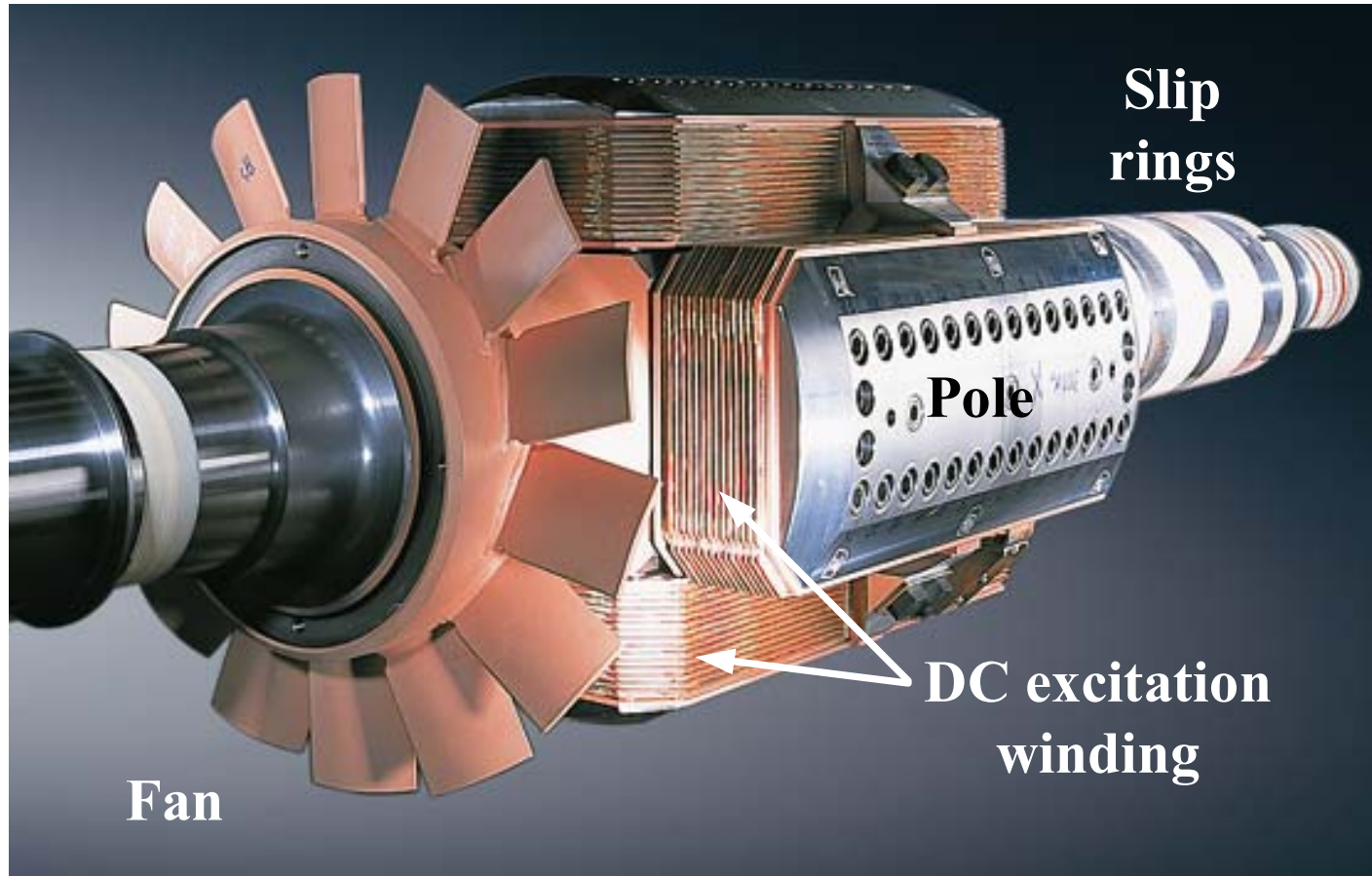

Rotor of a four-pole salient pole generator.

Synchronous Machines

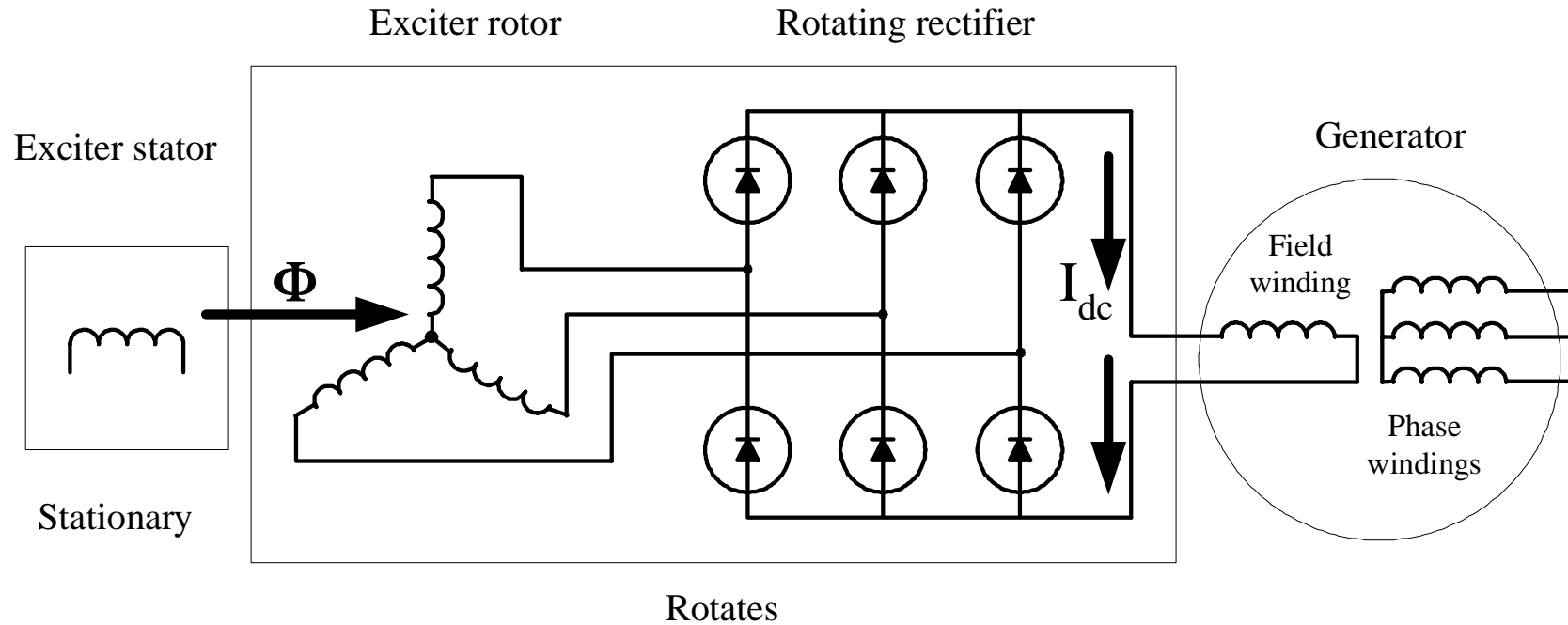

Concept of the brushless exciter system

Operating Concept

Synchronous Machines

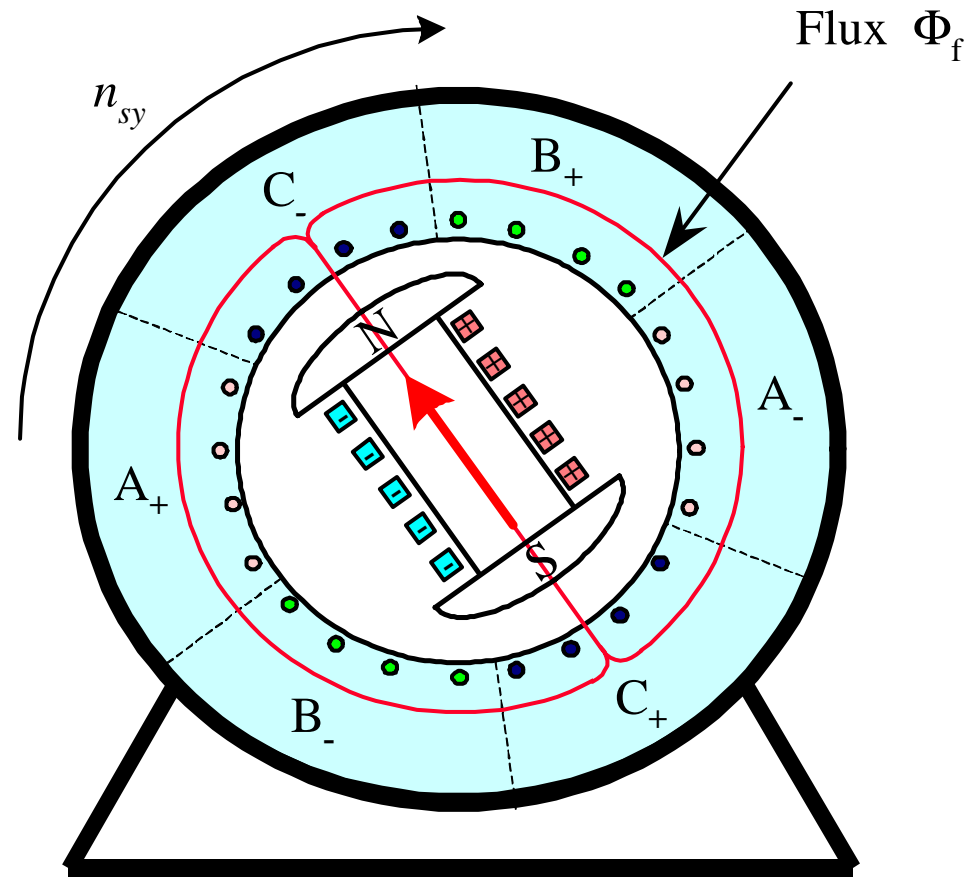

Operating concept of a synchronous generator

Synchronous Machines

Maximum flux linkage with phase A

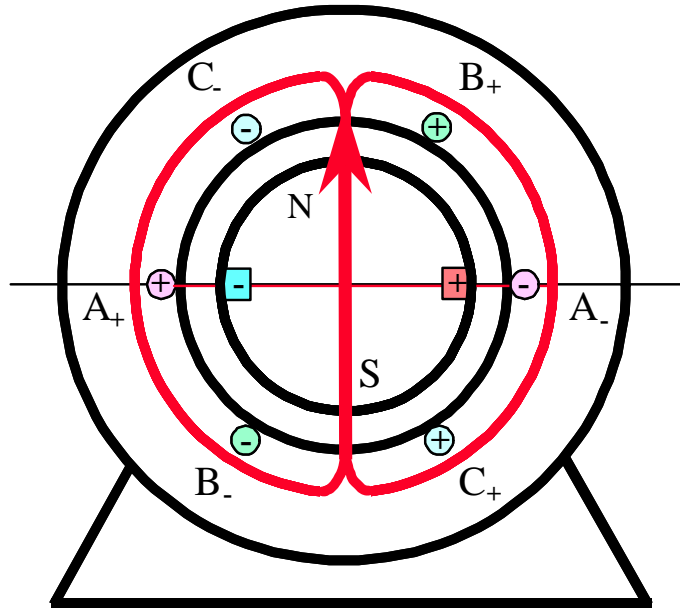

(a) Flux is perpendicular to phase A

No flux linkage with phase A

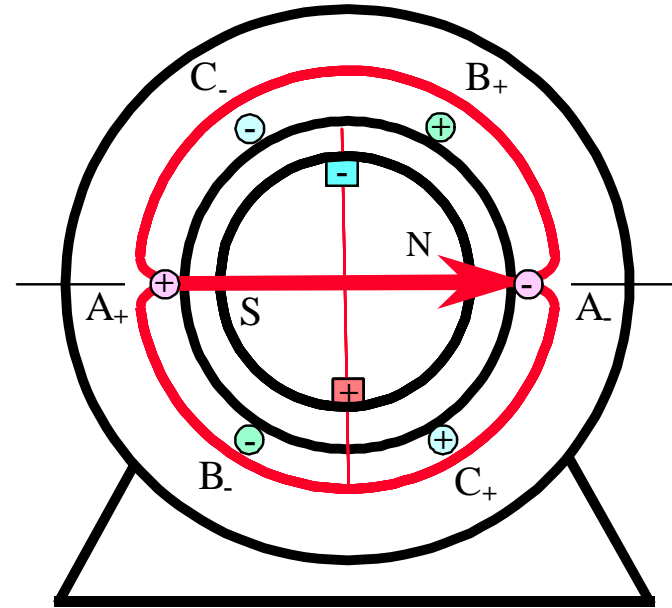

(b) Flux is parallel to phase A

Rotation produced flux linkage variation.

Synchronous Machines

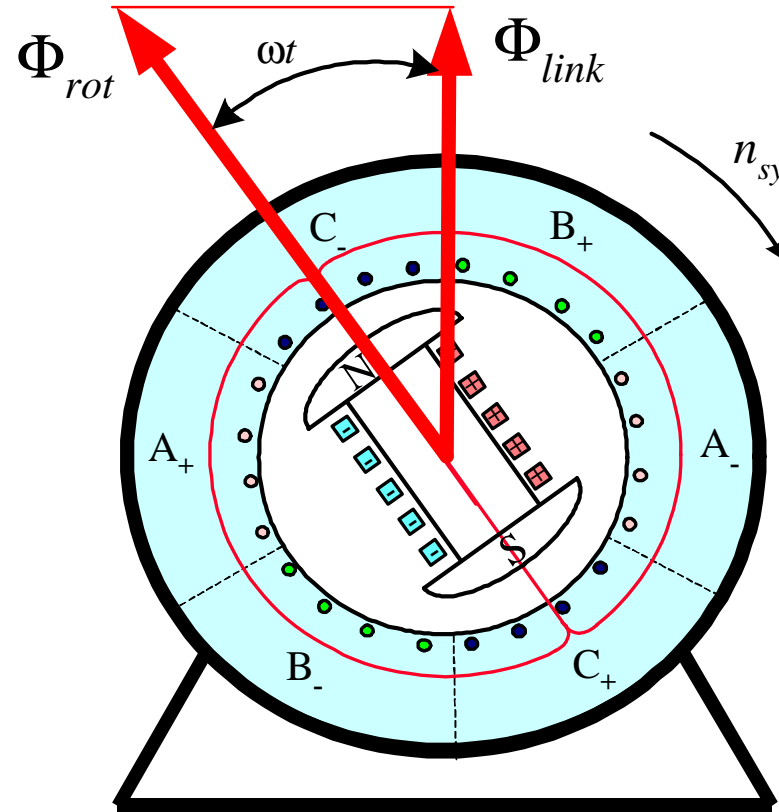

Rotating flux linkage to phase A.

Synchronous Machines

Main rotating flux

$$n_{sy} = \frac{f}{\frac{p}{2}}$$

$$\omega = 2\pi n_{sy}$$

$$\Phi_{link}(t) = \Phi_{rot} \cos(\omega t)$$

$$E_s(t) = N_{sta} \frac{d\Phi_{link}(t)}{dt}$$

$$\begin{aligned} E_s(t) &= -N_{sta} \Phi_{rot} \omega \sin(\omega t) \\ &= N_{sta} \Phi_{rot} \omega \cos(\omega t + 90^\circ) \end{aligned}$$

$$E_{sta} = \frac{N_{sta} \Phi_{rot} \omega}{\sqrt{2}}$$

The rotating flux generates the induced voltage

Synchronous Machines

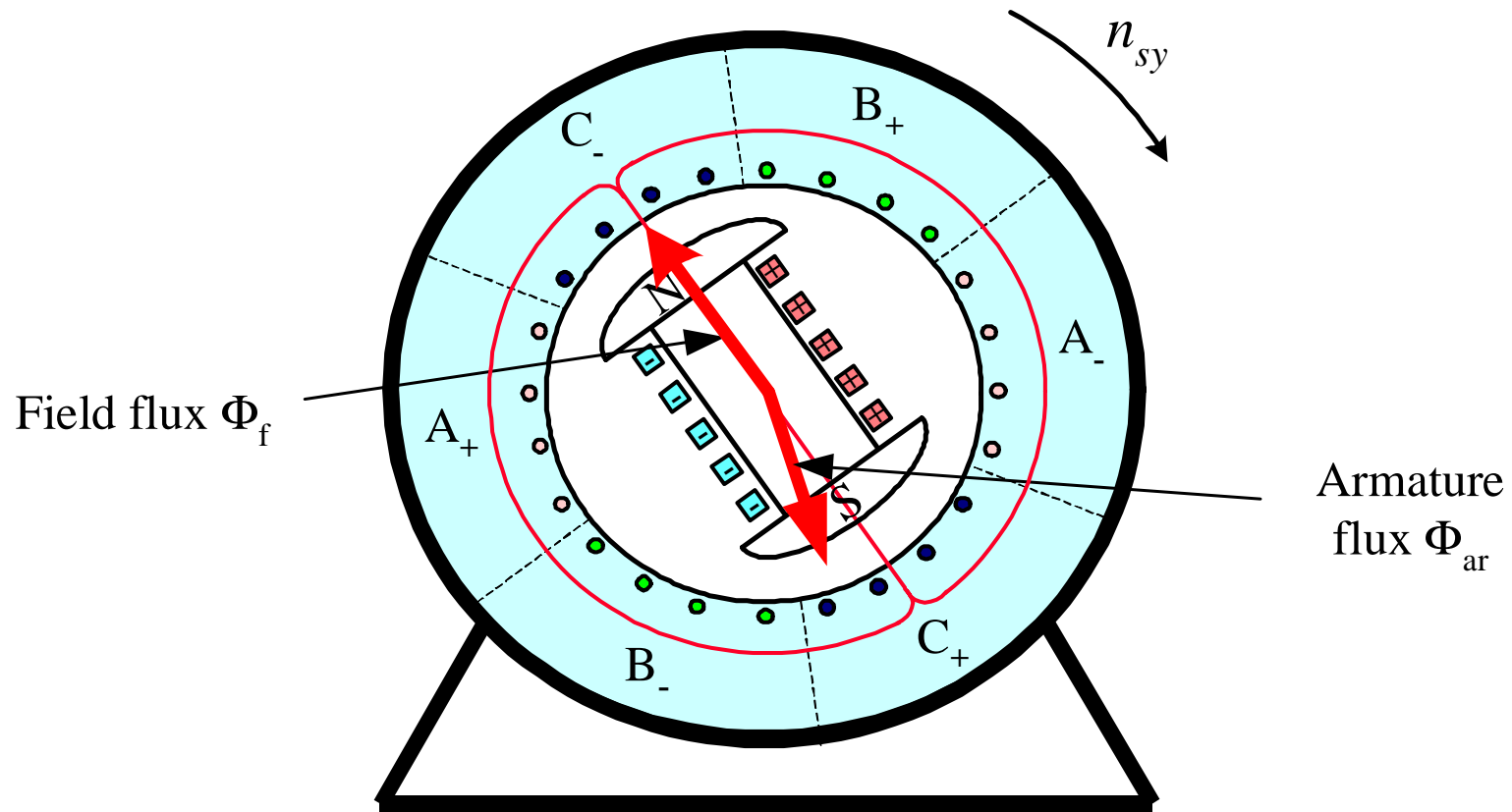

Field (Φ_f) and load generated (Φ_{ar}) rotating fluxes.

Synchronous Machines

Armature flux

$$I_{arm}(t) = \sqrt{2} I_{sta} \cos(\omega t)$$

$$\Phi_{arm}(t) = \Phi_{ar} \cos(\omega t)$$

$$E_{ar}(t) = N_{sta} \frac{d\Phi_{arm}(t)}{dt} = -N_{sta} \Phi_{ar} \omega \sin(\omega t)$$

$$E_{arm} = \frac{N_{sta} \Phi_{ar} \omega}{\sqrt{2}}$$

$$\mathbf{V}_t = \mathbf{E}_{sta} - \mathbf{E}_{arm}$$

Load current generates a rotating flux reducing the main flux and induced voltage

Synchronous Machines

Armature flux

$$\begin{aligned} E_{ar}(t) &= L_{arm} \frac{dI_{arm}(t)}{dt} = L_{arm} \frac{d}{dt} \sqrt{2} I_{sta} \cos(\omega t) \\ &= -L_{arm} \omega \sqrt{2} I_{sta} \sin(\omega t) \\ &= -X_{arm} \sqrt{2} I_{sta} \sin(\omega t) \end{aligned}$$

$$X_{arm} = \frac{N_{sta} \Phi_{ar} \omega}{\sqrt{2} I_{sta}}$$

$$X_{syn} = X_{arm} + X_{leakage}$$

Synchronous Machines

*Single phase
equivalent circuit*

$$\mathbf{E}_{arm-syn} = \mathbf{I}_{sta} (j X_{syn})$$

$$\mathbf{V}_t = \mathbf{E}_{sta} - \mathbf{E}_{arm-syn} = \mathbf{E}_{sta} - \mathbf{I}_{sta} j X_{syn}$$

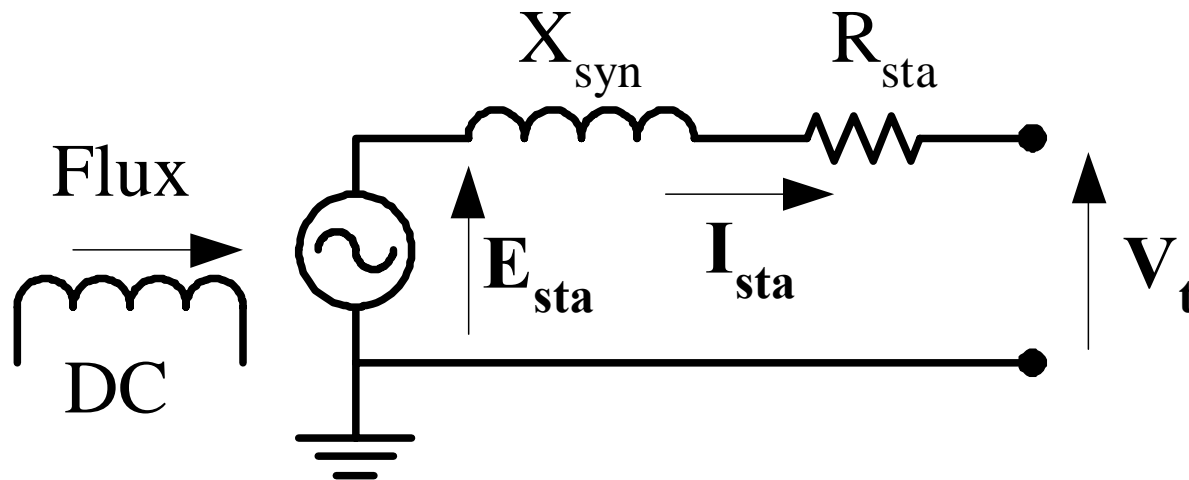

Single-phase equivalent circuit of a synchronous generator.

Synchronous Machines

- **The generator is loaded**
- **The load current produces a rotating flux**
- **This rotating flux induces a ac three phase voltage in the stator winding.**
- **This voltage is**
 - **subtracted from the induced voltage.**
 - **represented by a voltage drop on the synchronous reactance**
- **The equivalent circuit of a synchronous generator is a voltage source and a reactance connected in series**

Synchronous Machines

Generator Application

- **Power angle:** Angle between the dc excitation current generated induced voltage and the terminal voltage

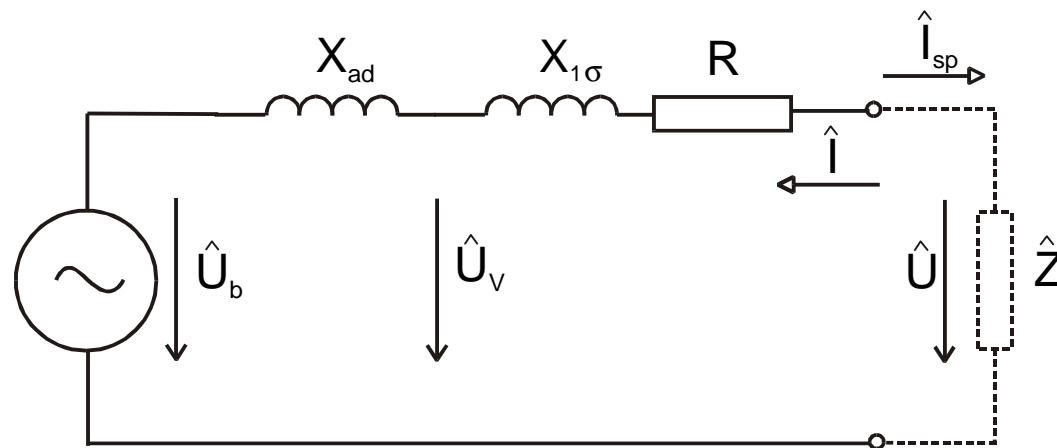

$$\hat{U} = \hat{U}_b + j X_{ad} \hat{I} + j X_{l\sigma} \hat{I} + R \hat{I}$$

Synchronous Machines

- Phasor diagram of synchronous machine

$$\hat{U} = \hat{U}_b + j X_{ad} \hat{I} + j X_{l\sigma} \hat{I} + R \hat{I}$$

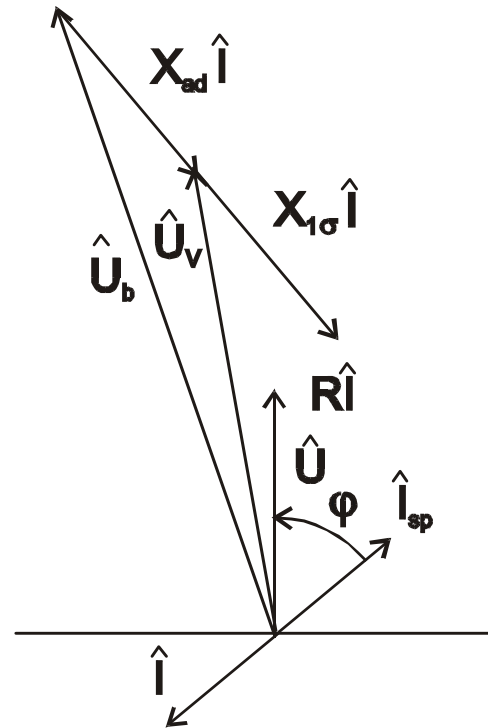

Synchronous Machines

Generator Application

- **Loading: power is less than angle 90 deg**
 - All generators in the system are connected in parallel
 - All generators rotates with the synchronous speed
 - The load can be increased by increasing the input mechanical power by regulating the turbine impute power
 - The speed does not change, the power angle increases
 - Maximum power angle is 90 degree, beyond that operation is unstable
- **Reactive power regulation**
- **When the excitation is:**
 - Increased, the generator reactive power also increases;
 - Decreased, the generator reactive power also decreases

- Load and excitation dependence

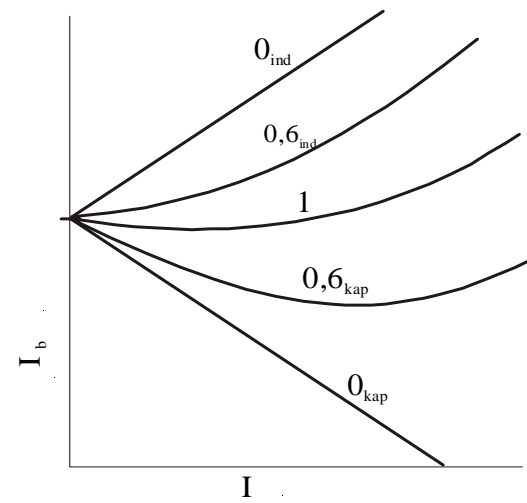
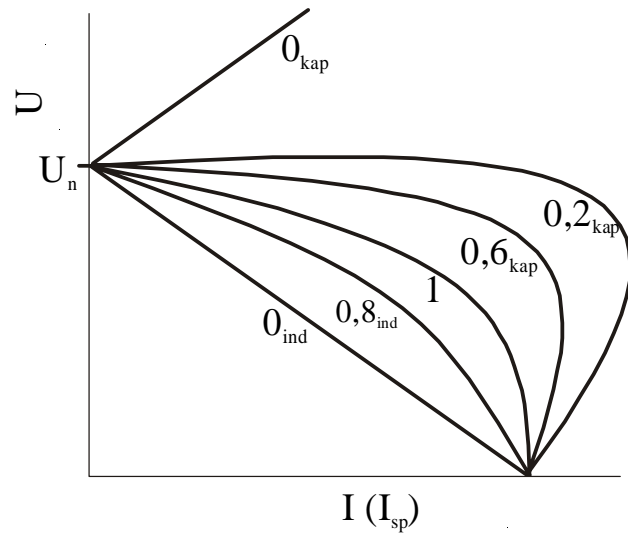

Synchronous Machines

Synchronization

- Verify that the phase sequences of the two systems are the same.
- Adjust the machine speed with the turbine that drives the generator until the generator voltage frequency is nearly the same as the frequency of the network voltage.
- Adjust the terminal voltage of the generator by changing the dc field (rotor) current until the generator terminal voltage is almost equal to the network voltage. Acceptable limit is 5%.
- Adjust the phase angle of the generator terminal voltage by regulating the input power until it is nearly equal with the phase angle of the network voltage. Acceptable limits are about 15° .

Synchronous Machines

- Synchronization

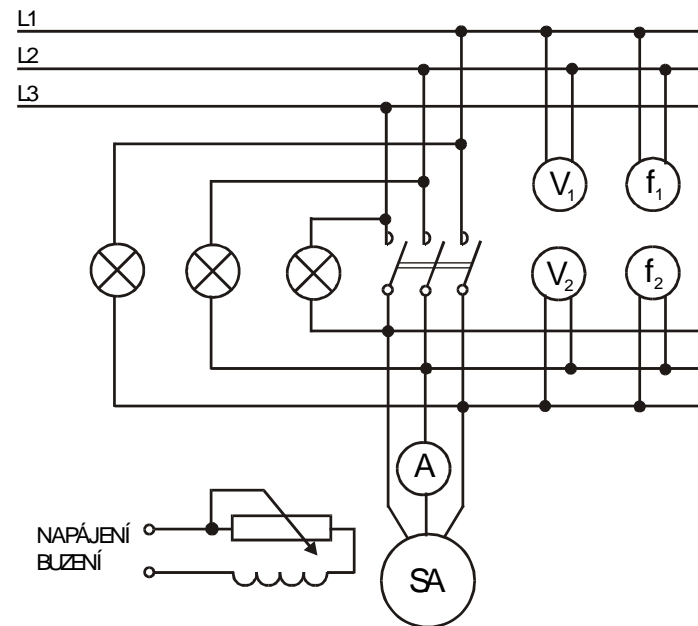

The generator and network power vs power angle

