

## VERTICAL DEFLECTION CIRCUITS FOR TV & MONITOR

---

By Alessandro MESSI

### SUMMARY

|  | <b>Page</b> |
|--|-------------|
| 1 INTRODUCTION.....  | 2           |
| 2 OSCILLATOR.....  | 3           |
| 3 RAMP GENERATOR.....  | 4           |
| 4 BLANKING GENERATOR AND CRT PROTECTION.....                       | 4           |
| 5 POWER AMPLIFIER STAGE.....                                       | 4           |
| 6 THERMAL PROTECTION.....  | 6           |
| 7 FLYBACK BEHAVIOUR.....   | 6           |
| 8 CURRENT - VOLTAGE CHARACTERISTICS OF THE RECIRCULATING DIODES .. | 11          |
| 9 CALCULATION PROCEDURE OF THE FLYBACK DURATION.....               | 12          |
| 10 APPLICATION INFORMATION.....                                    | 12          |
| 11 SUPPLY VOLTAGE CALCULATION.....                                 | 14          |
| 12 CALCULATION OF MIDPOINT AND GAIN.....                           | 17          |
| 13 MONITOR APPLICATIONS.....                                       | 20          |
| 14 POWER DISSIPATION.....  | 20          |
| 15 BLANKING PULSE DURATION ADJUSTMENT.....                         | 21          |
| 16 LINEARITY ADJUSTMENT.....                                       | 21          |
| 17 FACILITIES AND IMPROVEMENTS.....                                | 22          |
| 18 GENERAL APPLICATION AND LAYOUT HINTS.....                       | 23          |
| 19 REFERENCES.....   | 23          |

# VERTICAL DEFLECTION CIRCUITS FOR TV & MONITOR

## 1 - INTRODUCTION

In a general way we can define vertical stages circuits able to deliver a current ramp suitable to drive the vertical deflection yoke.

In Figure 1 is represented the more general possible block diagram of a device performing the vertical deflection.

Such a device will be called "complete vertical stage" because it can be simply driven by a synchronization pulse and it comprises all the circuitry necessary to perform the vertical deflection that is : oscillator, voltage ramp generator, blanking generator, output power and flyback generator.

At the right side of the dotted line in Figure 1 is represented the circuitry characterizing a "vertical output stage". This kind of device comprises only

the power stages and it has to be driven by a voltage sawtooth generated by a previous circuit (for example a horizontal and vertical synchronization stage).

In the first class there are the following devices : TDA1170D, TDA1170N, TDA1170S, TDA1175, TDA1670A, TDA1675, TDA1770A, TDA1872A, TDA8176.

In the second class there are : TDA2170, TDA2270, TDA8170, TDA8172, TDA8173, TDA8175, TDA8178, TDA8179.

There is also a third class of vertical stages comprising the voltage ramp generator but without the oscillator; these circuits must be driven by an already synchronized pulse. In this third class there are : TDA1771 and TDA8174.

**Figure 1 :** Block Diagram of a General Deflection Stage

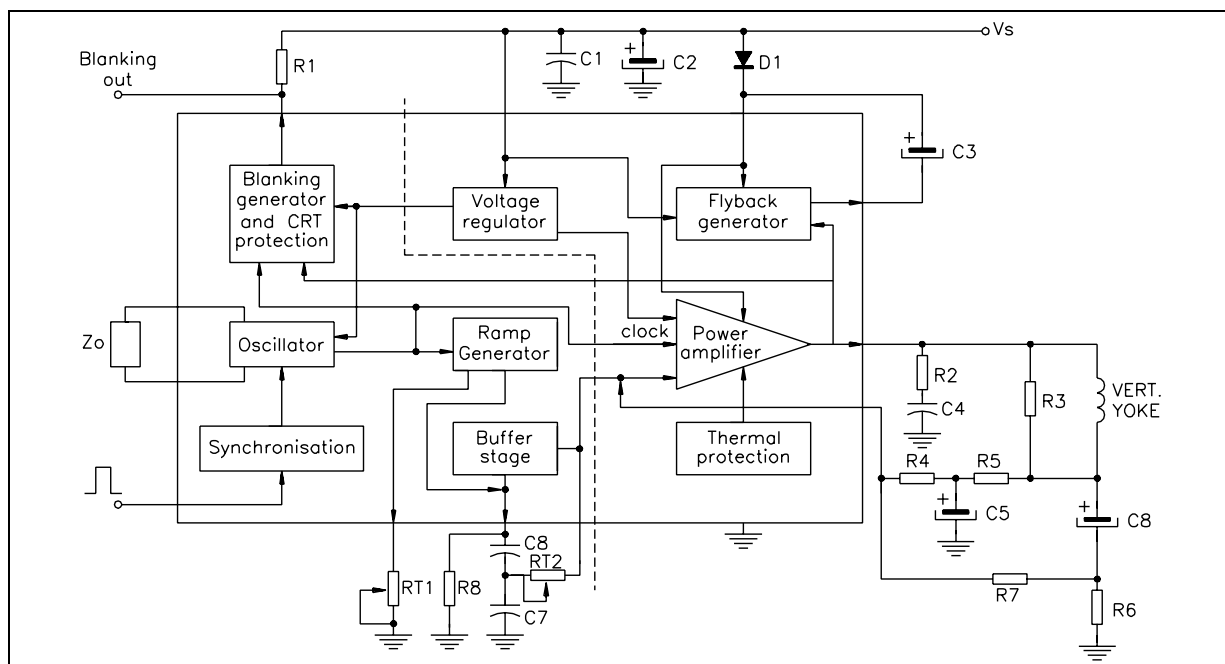

AN373-01 EPFS

2 - OSCILLATOR

There are two different kinds of oscillator stages used in SGS-THOMSON complete vertical deflections, one is used in TDA1170D, TDA1170N, TDA1170S, TDA1175 and TDA8176, the other in TDA1670A, TDA1675, TDA1170A and TDA1872A.

The principle of the first kind of oscillator is represented in Figure 2.

The following explanations will be the more general possible; we shall inform the reader when we refer to a particular device.

When the switches  $T_1$  and  $T_2$  are opened the  $C_0$  capacitor charges exponentially through  $R_0$  to the value  $V^+_{(MAX)}$  determined by the integrated resistors  $R_1$ ,  $R_2$ ,  $R_3$  and  $R_4$ . At this point the switches are closed, short-circuiting  $R_3$  and  $R_4$ , so the voltage at the non-inverting input becomes  $V^+_{(MIN)}$ . The capacitor  $C_0$  discharges to this value through the

integrated resistor  $R_5$ .

The free running frequency can be easily calculated resulting in :

$$T_0 = R_0 \cdot C_0 \cdot \log \frac{V_R - V^+_{(MIN)}}{V_R - V^+_{(MAX)}} + R_5 \cdot C_0 \cdot \log \frac{V^+_{(MAX)}}{V^+_{(MIN)}} \quad (1) \quad f_0 = \frac{1}{T_0}$$

with  $R_0 = 360 \text{ k}\Omega$  and  $C_0 = 100 \text{ nF}$ , it results in 43.7Hz.

The oscillator synchronization is obtained reducing the superior threshold  $V^+_{(MAX)}$  short-circuiting the  $R_4$  resistor when a vertical synchronization pulse occurs.

The second kind of oscillator is represented in Figure 3.

Figure 2 : First Kind of Oscillator Stage

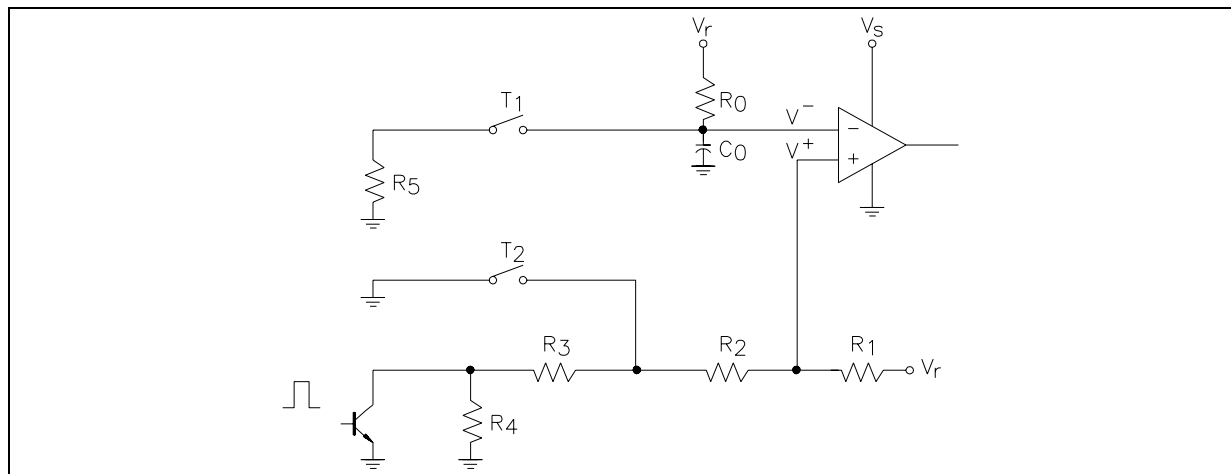

AN373-02.EPS

Figure 3 : Second Kind of Oscillator Stage

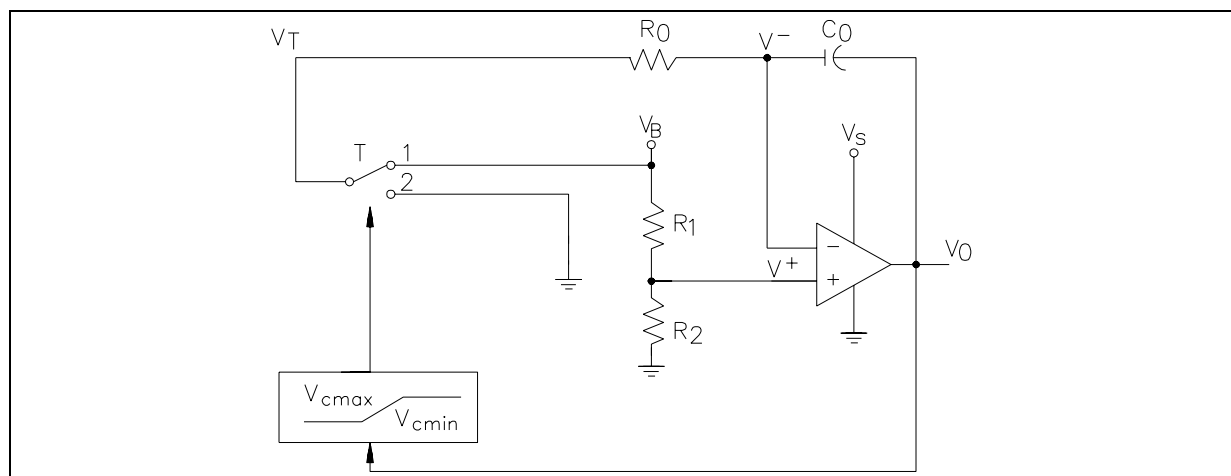

AN373-03.EPS

## VERTICAL DEFLECTION CIRCUITS FOR TV & MONITOR

When the switch T is in position 2, a constant current  $I_{CO} = V^- / R_O$  flows through  $C_O$  charging it with a voltage ramp. When the voltage  $V_O$  reaches  $V_{O(MAX)}$ , T passes in position 1, so a constant current  $I_{CO} = (V_B - V^-) / R_O$  discharges the capacitor causing the inversion of the voltage ramp slope at the output  $V_O(t)$ . The discharge stops when  $V_O$  reaches the value  $V_{O(MIN)}$  and the cycle takes place again.

It is possible to calculate the free running frequency  $f_O$  with the following formula :

$$T_O = \frac{(V_{O(MAX)} - V_{O(MIN)}) \cdot R_O \cdot C_O}{V^-} + \frac{(V_{O(MAX)} - V_{O(MIN)}) \cdot R_O \cdot C_O}{V_B - V^-} \quad (2)$$

with  $V_{O(MAX)} - V_{O(MIN)} = 3.9V$ ,  $V_B = 6.5V$ ,  $V^- = 0.445V$ ,  $R_O = 7.5k\Omega$  and  $C_O = 330nF$  it results in :  $f_O = 43.8Hz$ .

The oscillator synchronization is still obtained in the above mentioned way.

In order to guarantee a minimum pull-in range of 14Hz the threshold value has been chosen in  $V_P = 4.3V$ .

The spread of the free running frequency in this kind of oscillator is very low because it mainly depends from the threshold values  $V_{O(MAX)}$ ,  $V_{O(MIN)}$  and  $V^-$  that are determined by resistor rates that can be done very precise.

### 3 - RAMP GENERATOR

The ramp generator is conceptually represented in Figure 4.

The Voltage ramp is obtained charging the group  $R_1$ ,  $C_1$  and  $C_2$  with a constant current  $I_X$ .

It is easy to calculate the voltage  $V_{RAMP}$  That results in :

$$V_{RAMP}(t) = (V_{(MIN)} - R_1 \cdot I_X) e^{-\frac{1}{R_1 \cdot C + R_1 \cdot I_X}} \quad (3)$$

where  $V_{(MIN)}$  is the voltage in A when the charge starts and C is the series of  $C_1$  and  $C_2$ .

The resistor  $R_1$  is necessary to give a "C correction" to the voltage ramp. The ramp amplitude is determined by  $I_X = V_{REG} / P_1$ , so the potentiometer  $P_1$  is

necessary to perform the height control.

The voltage ramp is then transferred on a low impedance in B through a buffer stage.

The P2 potentiometer connected between D and B performs the ramp linearity control or "S correction" that is necessary to have a correct reproduction of the images on the TV set.

The voltage ramp in B grows up until the switch  $T_1$  is closed by a clock pulse coming from the oscillator; in this way the capacitors discharge fastly to  $V_{(MIN)}$  that is dependent upon the saturation voltage of the transistor that realizes the switch.

At this point the exponential charge takes place again.

### 4 - BLANKING GENERATOR AND CRT PROTECTION

This circuit senses the presence of the clock pulse coming from the oscillator stage and the flyback pulse on the yoke. If both of them are present a blanking pulse is generated able to blank the CRT during the retrace period. The duration of this pulse is the same of the one coming from the oscillator.

If for any reason the vertical deflection would fail, for instance for a short circuit or an open circuit of the yoke, the absence of the flyback pulse puts the circuit in such a condition that a continuous vertical blanking is generated in order to protect the CRT against eventual damages.

This circuit is available only in the following devices : TDA1670A, TDA1675, TDA1770A and TDA1872A.

The stages we will consider starting from this point are common both to complete vertical stages and vertical output stages.

### 5 - POWER AMPLIFIER STAGE

This stage can be divided into two distinct parts : the amplifier circuit and the output power.

The amplifier is realized with a differential circuit; a schematic diagram is represented in Figure 5.

The open-loop gain of the circuit is variable from 60dB to 90dB for the different integrated circuits.

The compensation capacitor C determines the dominant pole of the amplifier. In order to obtain a dominant pole in the range of 400Hz, the capacitor must be of about 10pF.

Figure 4 : Ramp Generator

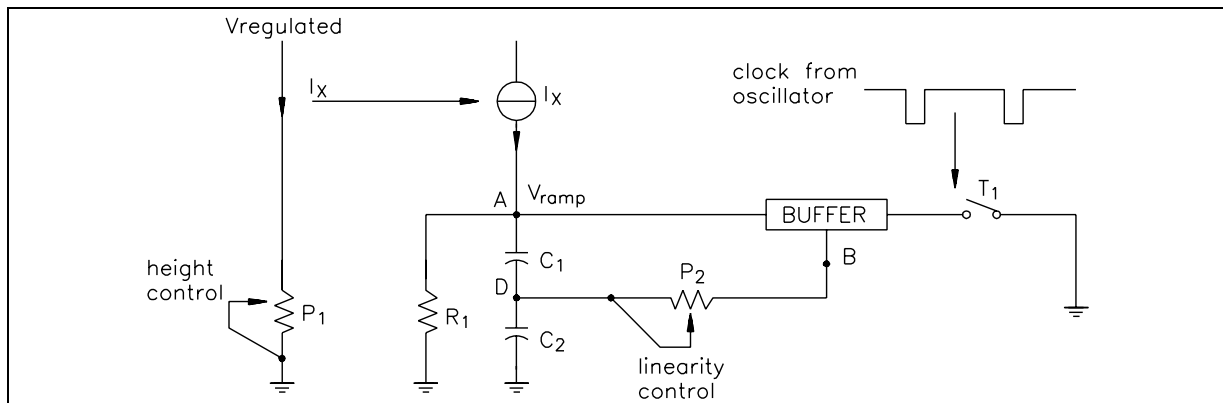

AN373-04.EPS

Figure 5 : Amplifier Stage

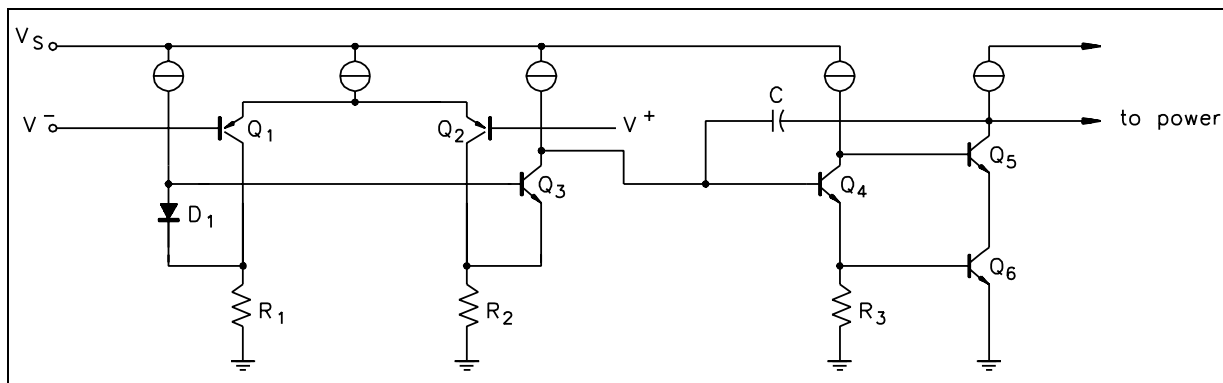

AN373-05.EPS

As an example in Figure 6 is represented the boole diagram of the amplifier open loop gain for TDA8172.

Figure 6 : Amplifier Open Loop Gain and Phase

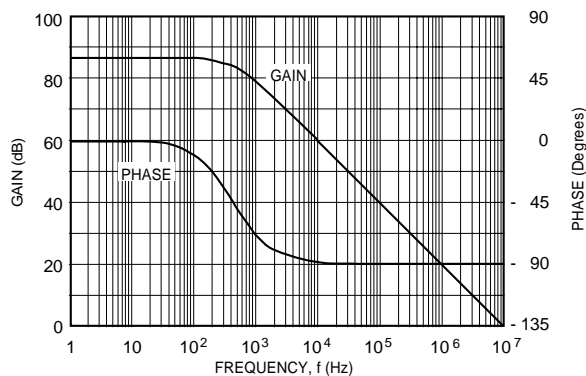

AN373-06.EPS

The output power stage is designed in order to deliver to the yoke a vertical deflection current from 1 to 2 A peak, depending upon the different devices, and able to support flyback voltages up to 60V. A typical output stage is depicted in Figure 7.

Figure 7 : Power Stage

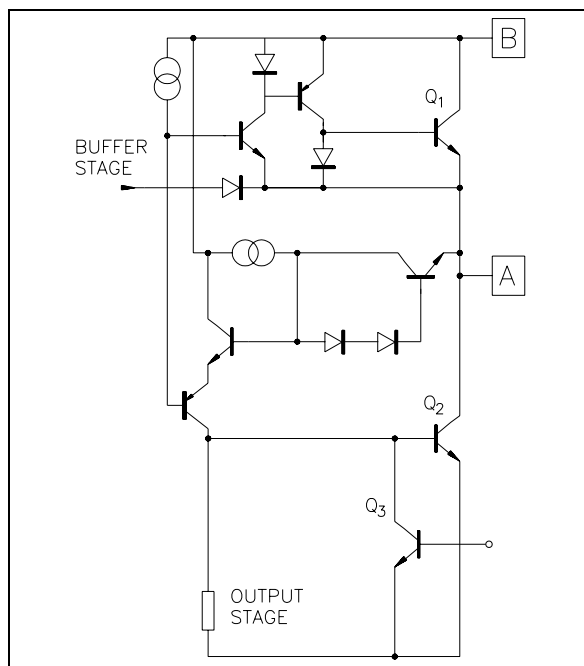

AN373-07.EPS

## VERTICAL DEFLECTION CIRCUITS FOR TV & MONITOR

The upper power transistor  $Q_1$  conducts during the first part of the scanning period when the vertical deflection current is flowing from the supply voltage into the yoke; when the current becomes negative, that is it comes out of the yoke, it flows through the lower power transistor  $Q_2$ . The circuit connected between the two output transistors is necessary to avoid distortion of the current at the crossing of zero, when  $Q_1$  is turned off and  $Q_2$  is turned on.

When the flyback begins,  $Q_2$  is switched-off by  $Q_3$  in order to make it able to support the high voltage of the flyback pulse.

The circuit behaviour during flyback is explained in chapter 7.

### 6 - THERMAL PROTECTION

The thermal protection is available in all the devices except the TDA1170 family and the TDA8176.

This circuit is useful to avoid damages at the integrated circuit due to a too high junction temperature caused by an incorrect working condition.

It is possible to sense the silicon temperature because the transistor  $V_{BE}$  varies of  $-2 \text{ mV}/^\circ\text{C}$ , so a

temperature variation can be reconducted to a voltage variation.

If the temperature increases and it is reaching  $150^\circ\text{C}$ , the integrated circuit output is shut down by putting off the current sources of the power stage.

### 7 - FLYBACK BEHAVIOUR

In order to obtain sufficiently short flyback times, a voltage greater than the scanning voltage must be applied to the deflection yoke.

By using a flyback generator, the yoke is only supplied with a voltage close to double the supply during flyback.

Thus, the power dissipated is reduced to approximately one third and the flyback time is halved.

The flyback circuit is shown in Figure 8 together with the power stage.

Figure 9 shows the circuit behavior, to show operation clearly. The graphs are not drawn to scale. Certain approximations are made in the analysis in order to eliminate electrical parameters that do not significantly influence circuit operations.

**Figure 8 : Output Power and Flyback Stages**

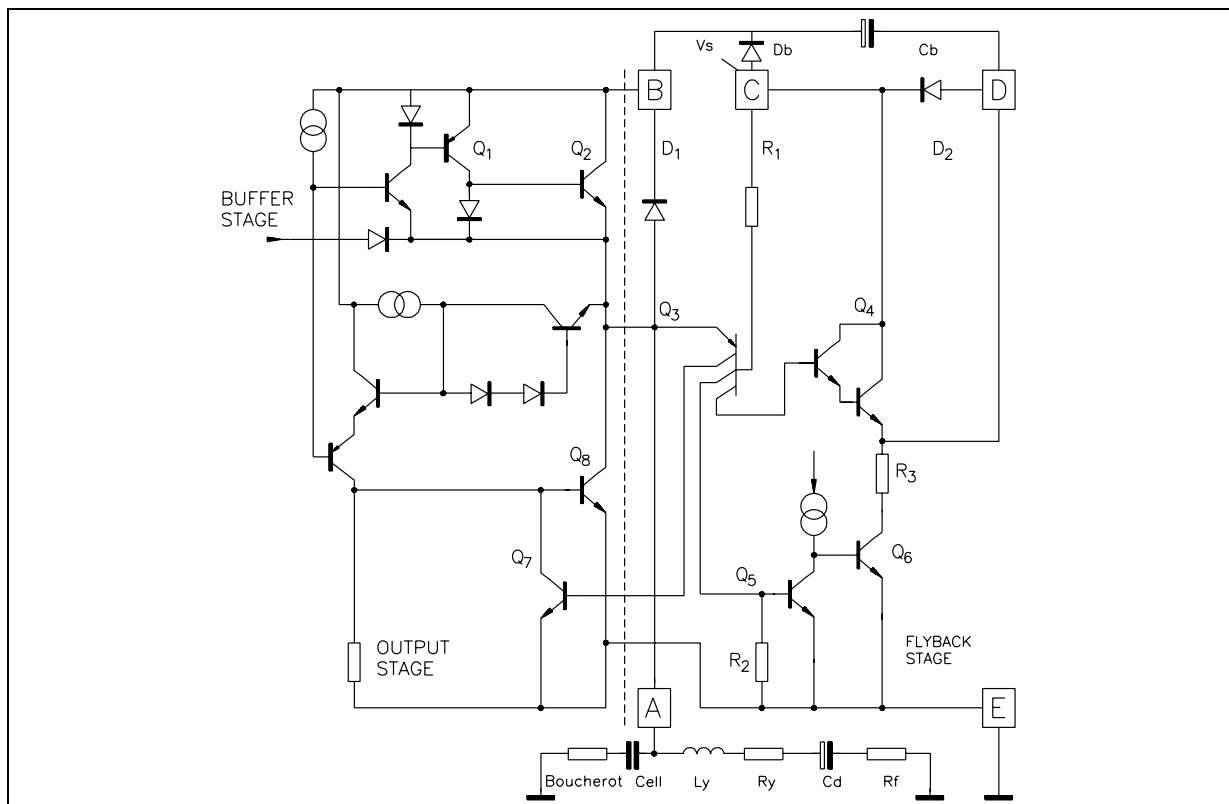

## VERTICAL DEFLECTION CIRCUITS FOR TV & MONITOR

**Figure 9 :** Current in the Yoke and Voltage Drop on The Yoke during Vertical Deflection

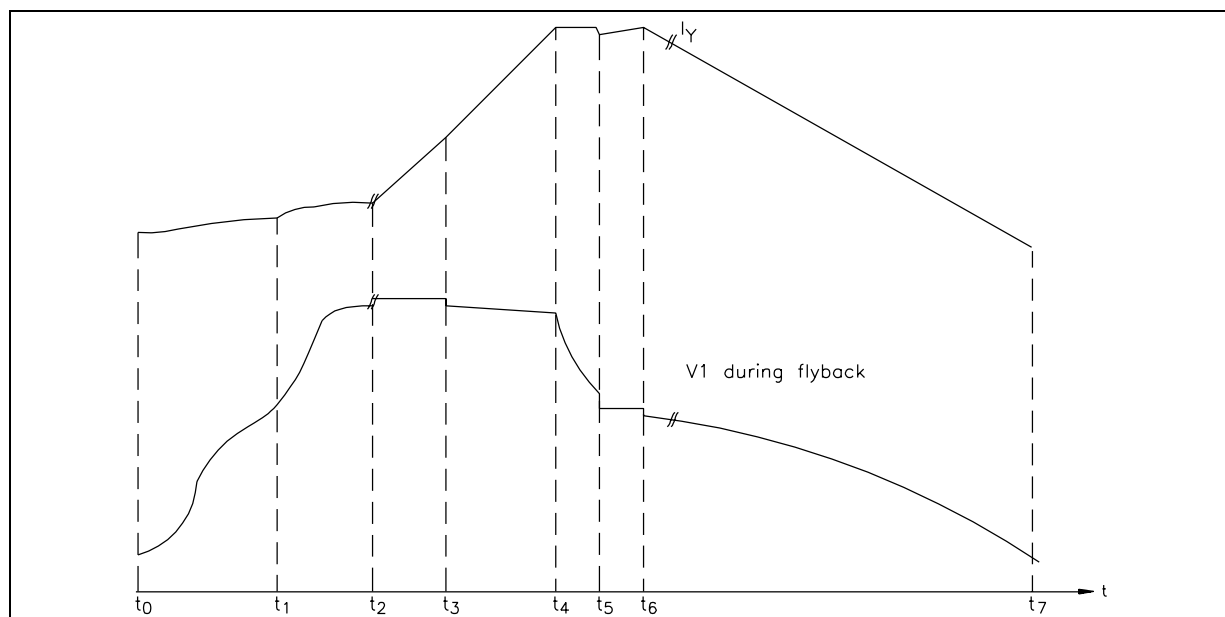

AN373-09.EPS

**a) Scan period ( $t_6 - t_7$ ) :** Figure 10

During scanning  $Q_3$ ,  $Q_4$  and  $Q_5$  are off and this causes  $Q_6$  to saturate.

A current from the voltage supply to ground flows through  $D_B$ ,  $C_B$  and  $Q_6$  charging the  $C_B$  capacitor up to :

$$V_{C_B} = V_S - V_{D_B} - V_{Q_6SAT} \quad (4)$$

At the end of this period the scan current has reached its peak value ( $I_P$ ) and it is flowing from the yoke to the device. At the same time  $V_A$  has reached its minimum value.

In Figures 11 and 12 are depicted the voltage drop

on the yoke and the currents flowing through  $D_B$  and the yoke.

**Figure 10 :** Circuit involved during Scan Period

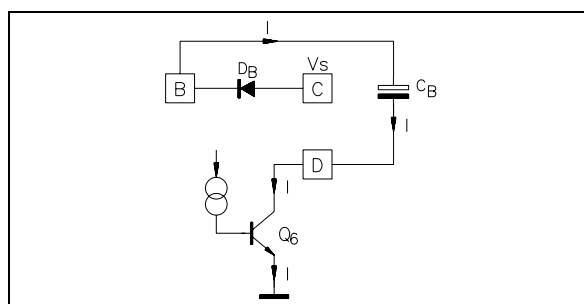

AN373-10.EPS

**Figure 11 :** Voltage Drop on the Yoke and Current Flowing through  $D_B$

$V = 10V/div.$  -  $I = 0.5A/div.$   
 $t = 2ms/div.$

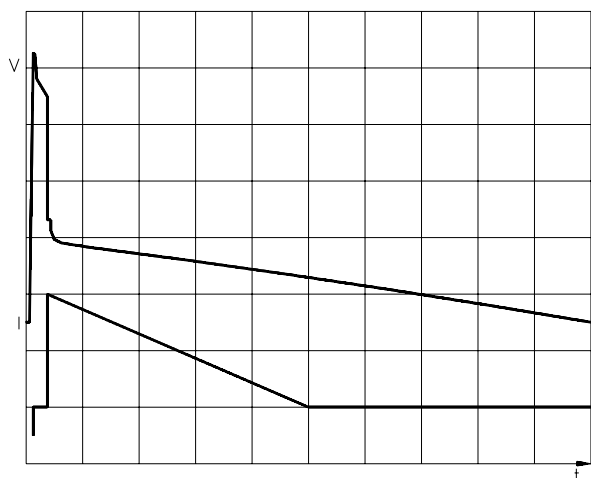

AN373-11.EPS

**Figure 12 :** Voltage Drop on the Yoke and Current Flowing through the Yoke

$V = 10V/div.$  -  $I = 1A/div.$   
 $t = 5ms/div.$

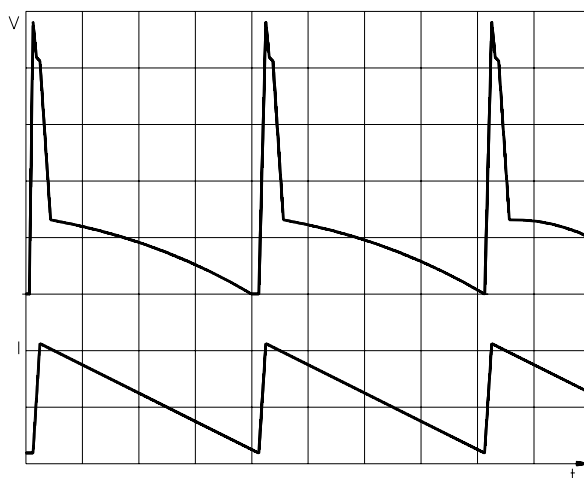

AN373-12.EPS

## VERTICAL DEFLECTION CIRCUITS FOR TV & MONITOR

### b) Flyback starting ( $t_0 - t_1$ ) : Figure 13

$Q_8$ , that was conducting the  $-I_P$  current, is turned off by the buffer stage.

The yoke, charged to  $I_P$ , now forces this current to flow partially through the Boucherot cell ( $I_1$ ) and partially through  $D_1$ ,  $C_B$  and  $Q_6$  ( $I_2$ ).

In Figures 14, 15 and 16 are represented the currents flowing through the yoke, the Boucherot cell and  $D_1$ .

**Figure 13 :** Circuit involved during Flyback Starting

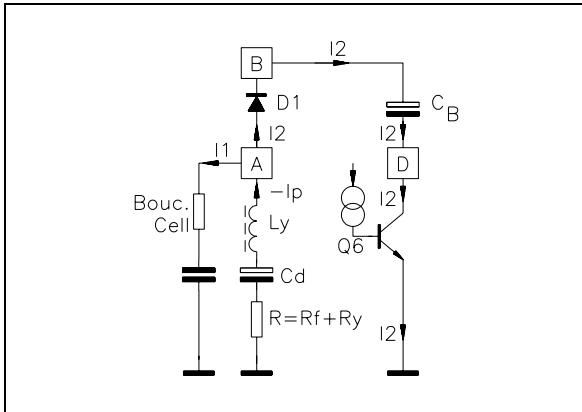

AN373-13.EPS

### c) Flyback starting ( $t_1 - t_2$ )

When the voltage drop at pin A rises over  $V_S$ ,  $Q_3$  turns on and this causes  $Q_4$  and  $Q_5$  to saturate. Consequently  $Q_6$  turns off.

During this period the voltage at pin D is forced to :

$$V_D = V_S - V_{Q4SAT} \quad (5)$$

Therefore the voltage at pin B becomes :

$$V_B = V_{CB} + V_D \quad (6)$$

The yoke current flows in the Boucherot cell added to another current peak flowing from  $V_S$  via  $Q_4$  and  $C_B$  (Figures 14 and 15).

**Figure 14 :** Voltage Drop on the Yoke and Current Flowing through the Boucherot Cell -  $V = 10V/div.$

$I = 1A/div. - t = 1\mu s/div.$

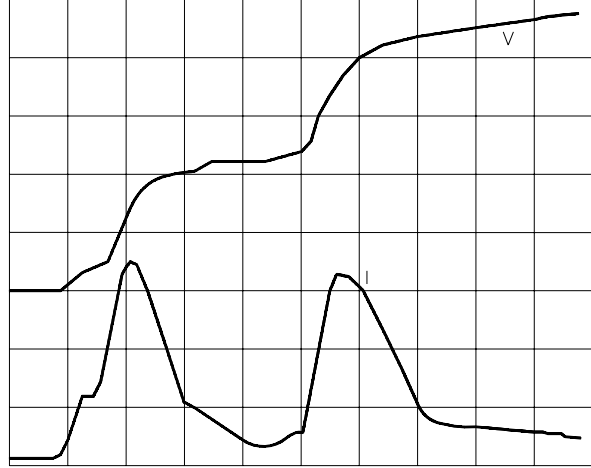

AN373-14.EPS

**Figure 15 :** Voltage Drop on the Yoke and Current Flowing through  $D_1$

$V = 10V/div. - I = 1A/div.$

$t = 1\mu s/div.$

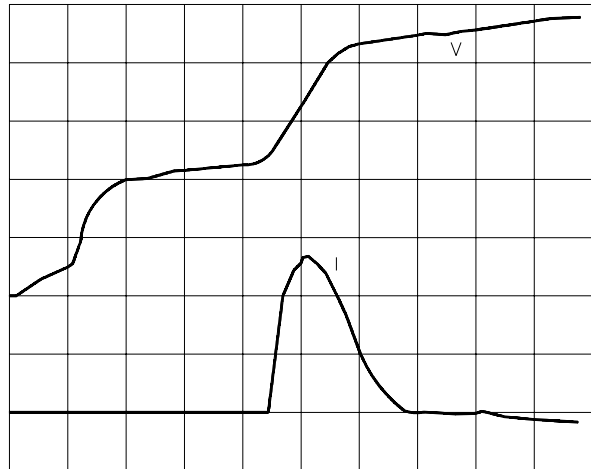

AN373-15.EPS

**Figure 16 :** Voltage Drop on the Yoke and Current Flowing through the Yoke  
 $V = 10V/div.$  -  $I = 100mA/div.$   
 $t = 1\mu s/div.$

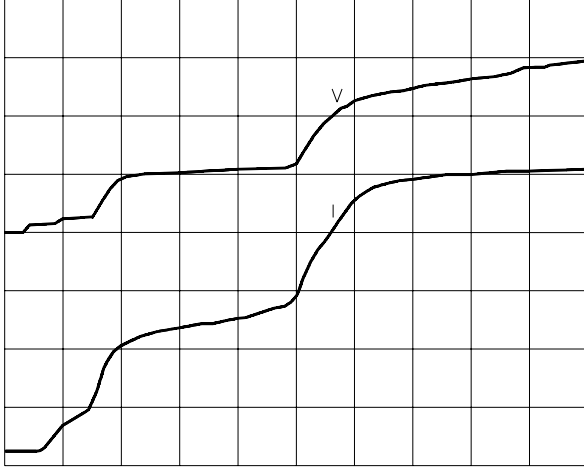

AN373-16.EPS

**d) Negative current rise ( $t_2 - t_3$ ) :** Figure 17

**Figure 17 :** Circuit involved during the Negative Current Rise

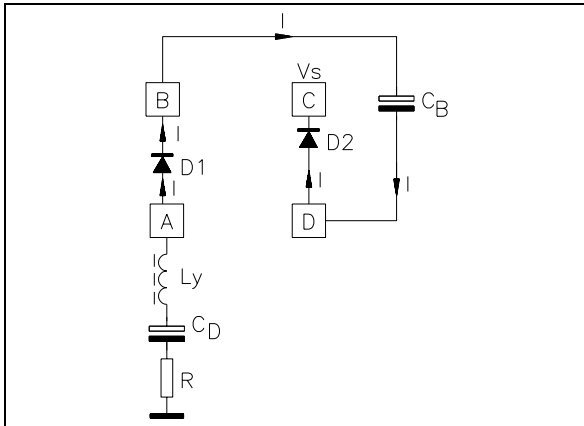

AN373-17.EPS

During this period, the voltage applied at pin A is :

$$\begin{aligned} V_A &= V_B + V_{D1}, \\ V_A &= V_{CB} + V_D + V_{D1}, \\ V_A &= V_S - V_{DB} - V_{Q6SAT} + V_S + V_{D2} + V_{D1}, \\ V_A &= 2 \cdot V_S + V_{D1} + V_{D2} - V_{DB} - V_{Q6SAT} \end{aligned} \quad (7)$$

It is possible to calculate the current solving the following equation :

$$V_A = L_Y \frac{di}{dt} + \frac{1}{C_D} \int i \cdot dt + R \cdot i \quad (8)$$

where  $R = R_F + R_Y$

Because the voltage at pin A is approximately constant (error less than 2%) we can simplify the (8) in the following equation :

$$\frac{d^2 i}{dt^2} + \frac{R}{L_Y} \frac{di}{dt} + \frac{1}{L_Y C_D} i = 0 \quad (9)$$

it results in :

$$\begin{aligned} i(t) &= \frac{I_P}{e^{2\beta\Delta T_1} - 1} e^{(-\alpha + \beta)t} \\ &- \frac{I_P}{1 - e^{-2\beta\Delta T_1}} e^{(-\alpha - \beta)t} \end{aligned} \quad (10)$$

where :

$$\alpha = \frac{R}{2 L_Y} \quad \beta = \sqrt{\frac{R^2}{4 \cdot L_Y^2} - \frac{1}{L_Y C_D}} \quad \Delta T_1 = t_3 - t_2$$

Because of  $\Delta T_1$  is two orders of magnitude lower than the scan time, we can apply an exponential sum to obtain the following equation :

$$i(t) = \frac{\alpha \cosh(2\beta\Delta T_1) + \beta \sinh(2\beta\Delta T_1) - \alpha}{\cosh(2\beta\Delta T_1) - 1} t - I_P \quad (11)$$

Simplifying :

$$i(t) = I_P \left( \alpha + \frac{1}{\Delta T_1} \right) t - I_P \quad (12)$$

The slope of the current is therefore :

$$\frac{di}{dt} = \left( \frac{R}{2 L_Y} + \frac{1}{\Delta T_1} \right) I_P \text{ (A/s)} \quad (13)$$

The current flows from the yoke to  $V_S$  through  $D_1$ ,  $C_B$  and  $D_2$ , and it is depicted in Figure 18.

**Figure 18 :** Voltage Drop on the Yoke and Current Flowing through the Yoke  
 $V = 10V/div.$  -  $I = 250mA/div.$   
 $t = 100\mu s/div.$

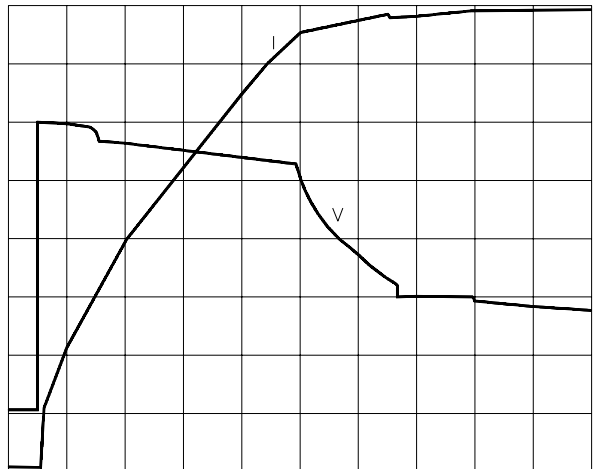

AN373-18.EPS

## VERTICAL DEFLECTION CIRCUITS FOR TV & MONITOR

e) Positive current rise ( $t_3 - t_4$ ) : Figure 19

**Figure 19 :** Circuit involved during the Positive Current Rise

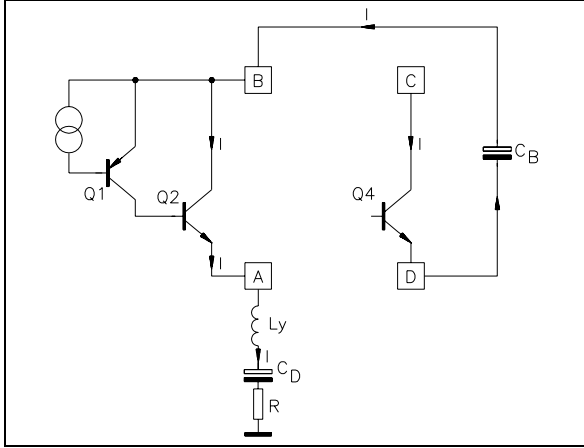

When the current becomes zero,  $D_1$  turns off and  $Q_2$  saturates ; so the pin A voltage becomes :

$$\begin{aligned} V_A &= V_B - V_{Q2SAT} \\ V_A &= 2 \cdot V_S - V_{DB} - V_{Q6SAT} - V_{Q4SAT} - V_{Q2SAT} \end{aligned} \quad (14)$$

The current flows from  $+V_S$  into the yoke through  $Q_4$ ,  $C_B$  and  $Q_2$  and rises from zero to  $I_P$  as it can be seen in Figure 18.

By using the previous procedure explained in section d), we can obtain the slope of the current :

$$\frac{di}{dt} = \left( \frac{R}{2L_Y} + \frac{1}{\Delta T_2} \right) I_P \text{ (A/s)}$$

where  $\Delta T_2 = t_4 - t_3$

f) Flyback decay ( $t_4 - t_5$ )

When the yoke current reaches its maximum peak,  $Q_2$  desaturates and conducts the maximum peak current flowing from  $V_S$  via  $Q_4$  and  $C_B$  into  $L_Y$ ; the current flowing through  $C_B$  is depicted in Figure 20.

**Figure 20 :** Voltage Drop on the Yoke and Current Flowing through  $C_B$   
 $V = 10V/div.$  -  $I = 0.5mA/div.$   
 $t = 100\mu s/div.$



**Figure 21 :** Voltage Drop on the Yoke and Current Flowing through the Boucherot Cell -  $V = 10V/div.$   
 $I = 100mA/div.$  -  $t = 100\mu s/div.$

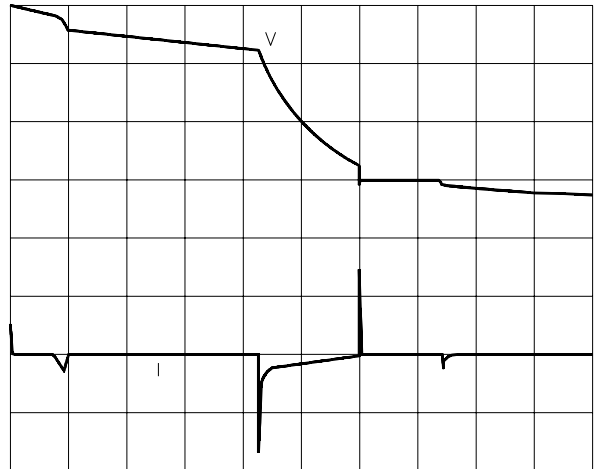

An eventual antiringing parallel resistor modify the linear decay slope in an exponential one, as it can be seen in Figure 22.

This continues until the buffer stage turns Q<sub>2</sub> on. The effect of the Boucherot cell during this periode is negligible (see Figure 21).

**Figure 22 :** Effect of Resistor in Parallel connected to the Yoke  
V = 10V/div.



**g) V<sub>A</sub> pedestal (t<sub>5</sub> - t<sub>6</sub>)**

When V<sub>A</sub> reaches the value V<sub>S</sub> of the supply voltage, the flyback generator stops its function.

Q<sub>3</sub> is turned off and turns off Q<sub>4</sub> that open the connection between pin D and V<sub>S</sub>.

Therefore V<sub>B</sub> drops to V<sub>S</sub> - V<sub>DB</sub> while :  
V<sub>A</sub> = V<sub>S</sub> - V<sub>DB</sub> - V<sub>Q2CE on</sub>

At this point the normal scan takes place.

**8 - CURRENT-VOLTAGE CHARACTERISTICS OF THE RECIRCULATING DIODES**

The following Figures 23 and 24 reproduce the I-V characteristics of the integrated recirculating diodes D<sub>1</sub> and D<sub>2</sub> (see Figure 8)

**Figure 23 :** I-V Characteristics of the Diode D<sub>1</sub>  
V = 500mV/div. - I = 200mA/div.

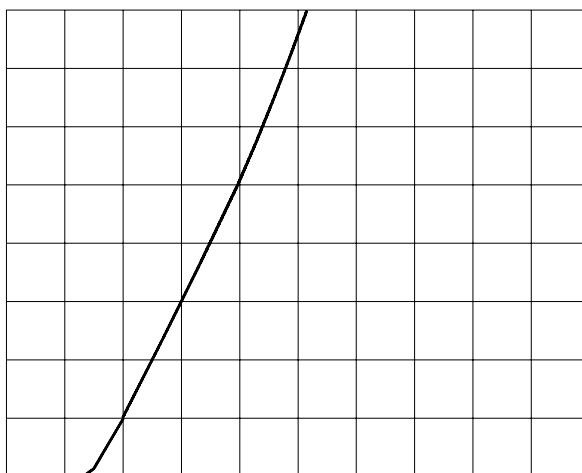

**Figure 24 :** I-V Characteristics of the Diode D<sub>2</sub>  
V = 500mV/div. - I = 200mA/div.

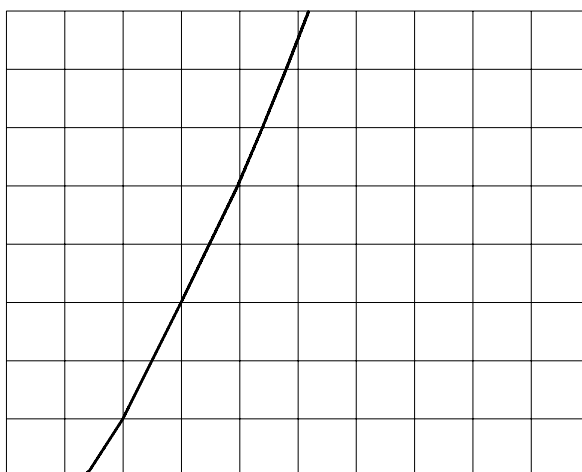

These characteristics are useful in order to calculate the maximum voltage reached at pin A with the formula (7) explained in chapter 7.

**9 - CALCULATION PROCEDURE OF THE FLYBACK DURATION**

The flyback duration can be calculated using the following procedure (referring to Figure 25).

**Figure 25 :** Circuit involved in the Calculation of Flyback Duration

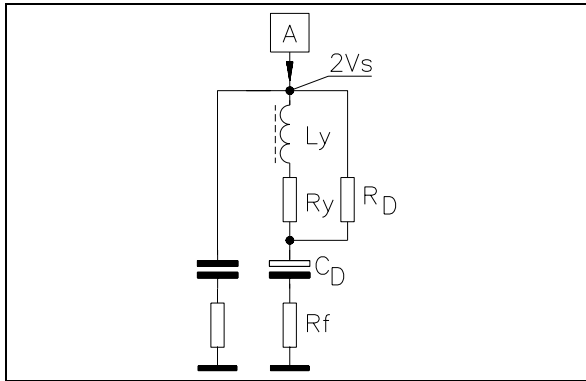

During the flyback period the voltage applied at pin A is about  $2 V_s$ , as previously explained in chapter 7. The voltage drop across  $C_D$  is approximately a constant voltage little less than  $V_s / 2$ . The voltage on the feedback resistor  $R_f$  is :

$$V_{R_f}(t) = R_f I_Y(t)$$

so in the period which we are considering it is negligible respect to  $V_s/2$ .

The effect of the Boucherot cell during this period is not sensible as it can be seen in Figure 21; while  $R_D$  acts principally during the flyback decay time (Figure 9:  $t_4 - t_5$ ) reducing its slope and the resulting oscillations but doesn't influence the total flyback time as shown in Figure 22. So their influences are also negligible.

Now the effective voltage drop across the yoke can be approximated to :

$$2 \cdot V_s - \frac{V_s}{2} = \frac{3}{2} V_s$$

Figure 25 can be simplified as shown in Figure 26.

**Figure 26 :** Simplified Circuit for the Calculation of Flyback Duration

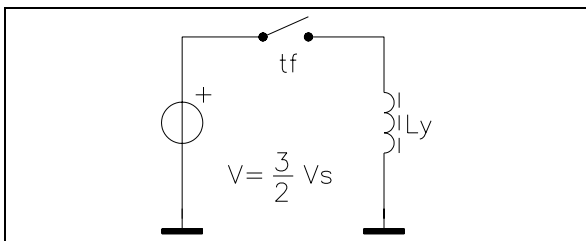

The voltage charges the coil with a linear current that can be calculated in the following way :

$$i(t) = \frac{1}{L_Y} \int V \cdot dt = \frac{1}{L_Y} \int \frac{3}{2} V_s \cdot dt \tag{16}$$

$$i(t) = \frac{1}{L_Y} \frac{3}{2} V_s \cdot t + K$$

K is calculated imposing that the current at the beginning of the flyback is  $-I_P$ .

$$i(0) = -I_P \quad K = -I_P \tag{17}$$

$$i(t) = \frac{3}{2} \frac{V_s}{L_Y} t - I_P$$

At the end of the flyback period the current will be  $+I_P$ , so we can write :

$$I_P = \frac{3}{2} \frac{V_s}{L_Y} t_F - I_P$$

The duration of the flyback period is then :

$$t_F = \frac{4}{3} \frac{I_P L_Y}{V_s} = \frac{2}{3} \frac{I_Y L_Y}{V_s} \tag{18}$$

**10 - APPLICATION INFORMATION**

The vertical deflection stages produced by SGS-THOMSON are able to cover the complete range of applications that the market need for color television and high/very high resolution monitors.

Television and monitor applications are not very different but in monitor field, in addition to the linearity and interlacing problems, we have to pay attention to the flyback time that must be very short for very high resolution models.

In television applications the most important requirement is to choose the lowest supply voltage possible in order to minimize the power dissipation in the integrated circuit, reducing the dimension of the heatsink, and the power dissipation from the voltage supplier.

These results can be reached very easily with SGS-THOMSON deflection stages because of the high efficiency of the flyback generator circuit used. In high resolution monitors one of the main problems is to reach the very short flyback time requested; the flyback generator, together with the high current and power dissipation capabilities, solve all the problems in a simple way.

In Figures 27, 28 and 29 are depicted three typical application circuits for the different kinds of integrated circuits available.

## VERTICAL DEFLECTION CIRCUITS FOR TV & MONITOR

**Figure 27 :** Application Circuit for TDA1170

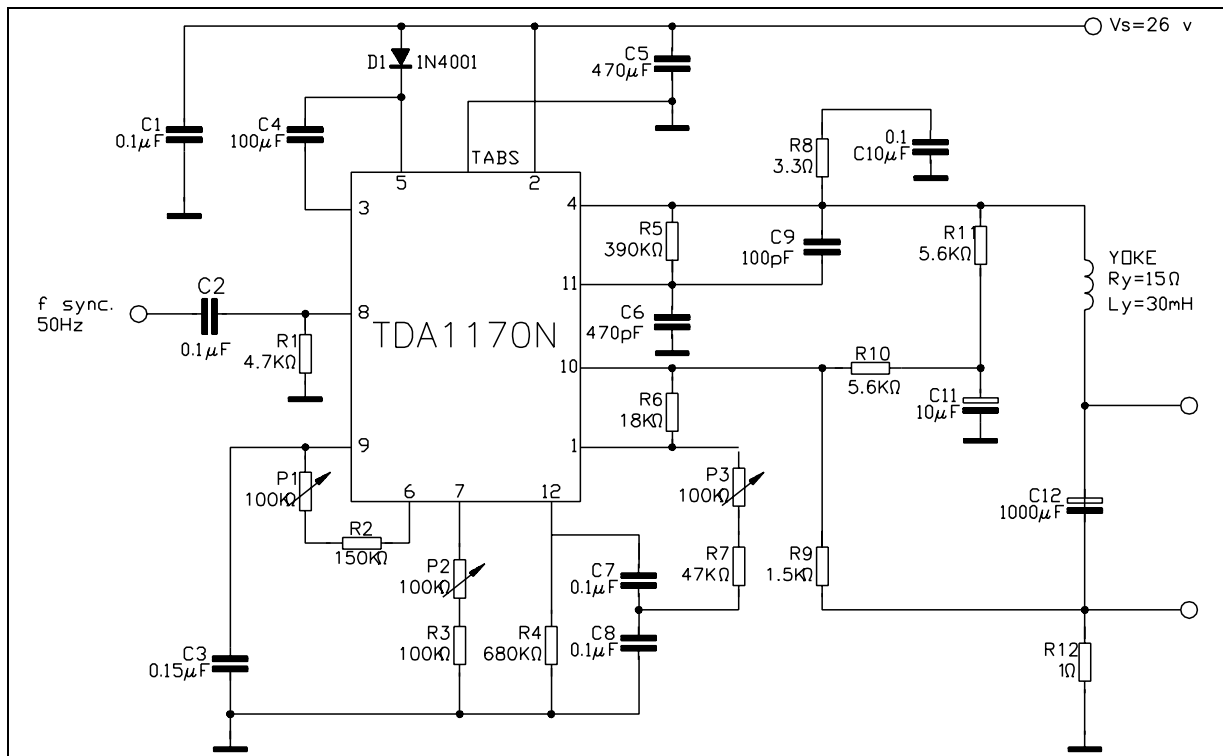

AN37-27.EPS

**Figure 28 :** Application Circuit for TDA1670A

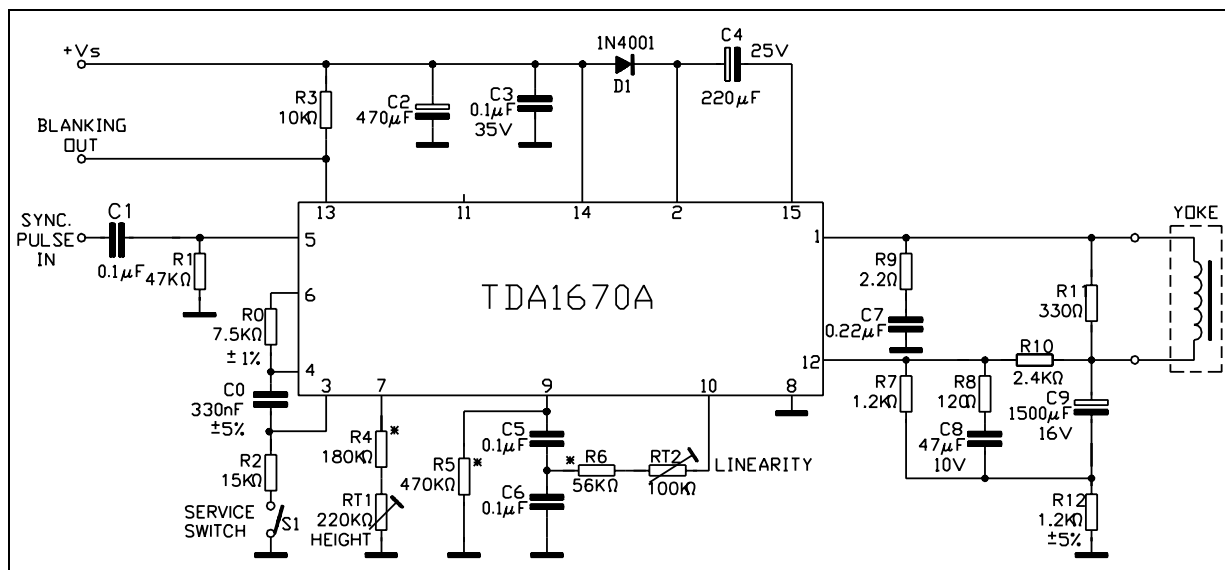

AN37-28.EPS

In the following chapters we shall do the calculation for television and monitor in order to choose the right voltage supply and external network for the yoke used and the current requirements.

## VERTICAL DEFLECTION CIRCUITS FOR TV & MONITOR

**Figure 29 :** Application Circuit for TDA8170

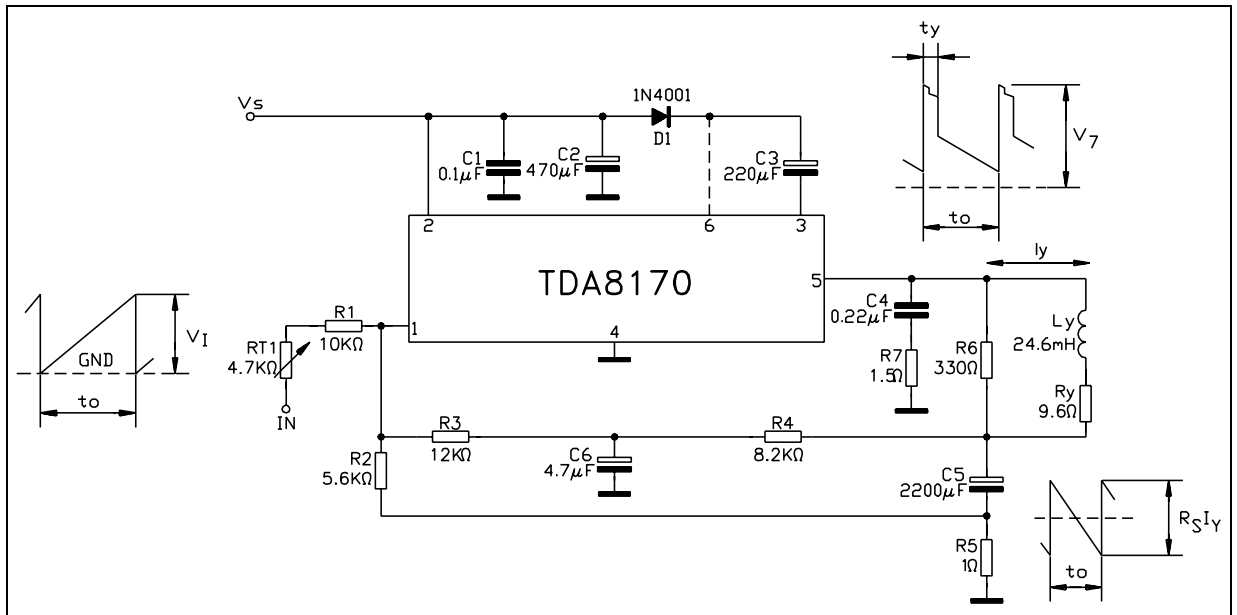

### 11 - SUPPLY VOLTAGE CALCULATION

For television applications we shall calculate the minimum supply voltage necessary to have vertical scanning knowing the yoke characteristics and the

current required for the given application.

Figure 30 shows the terms used in this section, while the circuit part involved in the following calculations is depicted in Figure 31.

**Figure 30 :** Parameters used in the Calculation of the Supply Voltage

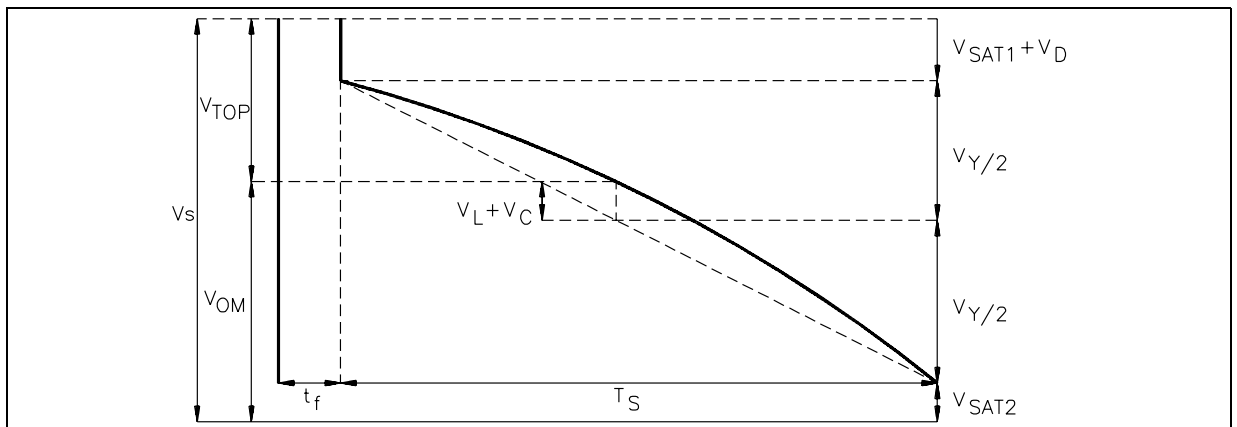

**Figure 31 :** Circuit involved in the Calculation of the Supply Voltage

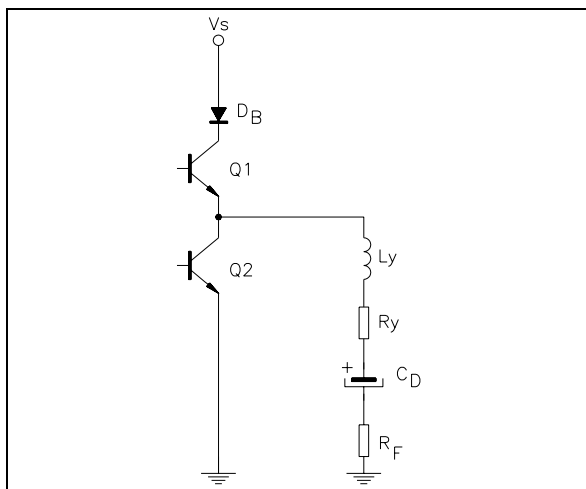

- $V_S$  = supply voltage
- $V_Y$  = nominal voltage required to produce the scanning current including the feedback resistance and the 20% increasing for temperature variations in the yoke current

$$V_Y = (1.2 R_Y + R_F) I_Y \quad (19)$$

- $V_{SAT1}$  = nominal output saturation voltage due to the upper power transistor  $Q_1$  (see Figure 32);
- $V_{SAT2}$  = nominal output saturation voltage due to the lower power transistor  $Q_2$  (see Figure 33)
- $V_{OM}$  = nominal quiescent voltage (midpoint) on the output power transistors
- $V_C$  = voltage peak due to the charge of  $C_D$  capacitor

$$V_C = \frac{I_Y \cdot t_s}{8 \cdot C_D} \quad (20)$$

- $V_L$  = voltage drop due to the yoke inductance  $L_Y$

$$V_L = \frac{L_Y \cdot I_Y}{t_s} \quad (21)$$

**Figure 32 :** Saturation Characteristic of the Upper Power Transistor

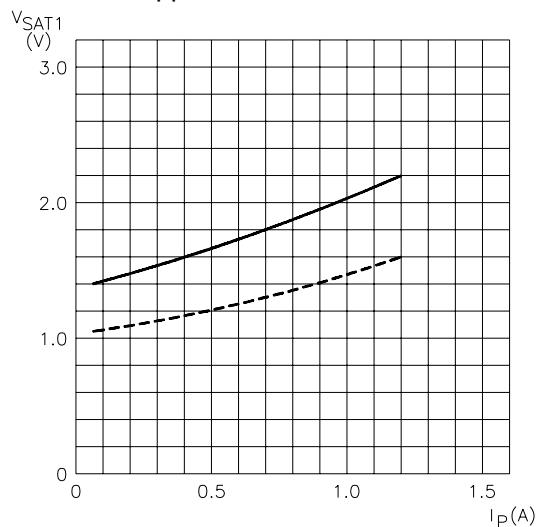

**Figure 33 :** Saturation Characteristic of the Lower Power Transistor

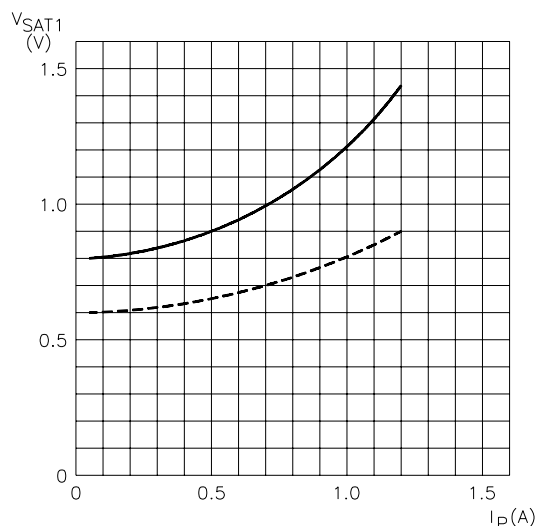

- $V_D$  = nominal voltage drop on  $D_B$  diode in series with the supply
- $T$  = vertical scan period
- $t_F$  = flyback time

$$t_F = \frac{2}{3} \frac{I_Y \cdot L_Y}{V_S}$$

## VERTICAL DEFLECTION CIRCUITS FOR TV & MONITOR

$t_s$  = scanning time

$$t_s = T - t_F$$

$I_Y$  = peak-to-peak deflection current

$R_Y$  = nominal yoke resistance

$L_Y$  = nominal yoke inductance

$R_F$  = feedback resistor

Referring to Figure 30 it is easy to see that the minimum supply voltage is given by

$$V_S = V_{OM} + V_{TOP} \quad (22)$$

where :

$$V_{OM} = \frac{V_Y}{2} + V_{SAT2} + V_C + V_L \quad (23)$$

and :

$$V_{TOP} = \frac{V_Y}{2} + V_D + V_{SAT1} - V_L - V_C \quad (24)$$

So we obtain :

$$V_S = V_Y + V_D + V_{SAT1} + V_{SAT2} \quad (25)$$

The (25) gives the minimum voltage supply if we do not consider the tolerances of the integrated circuit and of the external components, but the calculation, even if it was not realistic, it was useful in order to understand the procedure.

Now we shall do the same thing considering all the possible spreads; we can in this way obtain the real minimum supply voltage.

We shall follow the statistical composition of spreads because it is never possible that all of them are present at the same time with the same sign.

We must consider the following spreads :

- $\Delta V_Y$  due to the variation of yoke and feedback resistance and yoke current, supposing a 10% of regulation range in scanning current and a precision of 7% for resistors ;

$$\Delta V_Y = (1.2 R_Y + R_F) 1.07 (1.1 I_Y) - V_Y \quad (26)$$

- $\Delta V_C$  due to the tolerance of  $C_D$  and yoke current regulation ;

$$\Delta V_C = \frac{1.1 I_Y t_s}{8 C_{D(\min)}} - V_C \quad (27)$$

- $\Delta V_L$  due to the tolerance of  $L_Y$  ( $\pm 10\%$ ) and yoke current regulation;

$$\Delta V_L = \frac{1.1 I_Y 1.1 L_Y}{t_s} - V_L \quad (28)$$

$$\begin{aligned} \Delta V_{SAT1} &= V_{SAT1(\text{MAX})} - V_{SAT1} \\ \Delta V_{SAT2} &= V_{SAT2(\text{MAX})} - V_{SAT2} \end{aligned}$$

For each parameter, it is necessary to calculate the factor  $\rho$ , expressing the percentual influence of every parameter variation on the nominal supply voltage, with the following formulas :

for  $V_{OM}$  :

$$\rho = \frac{\Delta V}{V_{OM}}$$

for  $V_{TOP}$  :

$$\rho = \frac{\Delta V}{V_{TOP}}$$

We have then to calculate the square mean root of the spreads expressed as :

$$\sqrt{\sum \rho^2}$$

So if we call :

$$V_{OM1} = V_{OM} \left( 1 + \sqrt{\sum \rho^2} \right)$$

and :

$$V_{TOP1} = V_{TOP} \left( 1 + \sqrt{\sum \rho^2} \right)$$

We can write :

$$V_S = V_{OM1} + V_{TOP1} \quad (29)$$

An example of calculation will better explain the procedure. We shall consider a 26", 110°, neck 29.1mm tube whose characteristics are :

$I_Y = 1.2 \text{ App}$ ,  
 $R_Y = 9.6\Omega \pm 7\%$ ,  
 $L_Y = 24.6\text{mH} \pm 10\%$ .

We shall use a coupling capacitance  $C_D$  of 1500 $\mu\text{F}$  with + 50% and - 10% tolerance and a feedback resistance  $R_F$  of 1.2 $\Omega$ .

**a) Nominal minimum supply voltage :**

$$V_Y = (1.2 R_Y + R_F) \quad I_Y = 15.264V$$

$$V_C = \frac{I_Y \cdot t_s}{8 \cdot C_D} = 2V$$

$$V_L = \frac{L_Y \cdot I_Y}{t_s} = 1.476V$$

$$V_{SAT1} = 1.25V \quad V_{SAT2} = 0.68V$$

$$V_D = 1V$$

$$V_{OM} = 11.788V \quad V_{TOP} = 6.406V$$

We obtain :  $V_S = 18.2V$

**b) Statistical minimum supply voltage :**

$$\Delta V_C = 2.702V$$

$$\rho V_{YM} = \frac{V_{Y/2}}{V_{OM}} \quad \rho^2 V_{YM} = 1.313 \cdot 10^{-3}$$

$$\rho V_{YT} = \frac{V_{Y/2}}{V_{TOP}} \quad \rho^2 V_{YT} = 4.447 \cdot 10^{-3}$$

$$\Delta V_C = 0.445V \quad \rho^2 V_{CM} = 1.421 \cdot 10^{-3}$$

$$\rho^2 V_{CT} = 4.813 \cdot 10^{-3}$$

$$\Delta V_L = 0.31V \quad \rho^2 V_{LM} = 6.914 \cdot 10^{-4}$$

$$\rho^2 V_{LT} = 2.341 \cdot 10^{-3}$$

$$\Delta V_{SAT1} = 0.45V \quad \rho^2 V_{SAT1T} = 4.935 \cdot 10^{-3}$$

$$\Delta V_{SAT2} = 0.27V \quad \rho^2 V_{SAT2T} = 5.246 \cdot 10^{-4}$$

$$V_{OM1} = V_{OM} (1 + \sqrt{\Sigma \rho^2}) = 13.268V$$

$$V_{TOP1} = V_{TOP} (1 + \sqrt{\Sigma \rho^2}) = 7.930V$$

$$V_S = V_{OM1} + V_{TOP1} = 21.2V$$

This is a real value for the minimum supply voltage needed by the above mentioned application.

In this case we obtain a flyback duration of about :

$$t_F = \frac{2}{3} \frac{I_Y \cdot L_Y}{V_S} \approx 900\mu s$$

**12 - CALCULATION OF MIDPOINT AND GAIN**

For the calculation of the output midpoint voltage, it is necessary to consider the different feedback network for the applications of the various integrated circuits.

We shall first consider the TDA1170 family, the

TDA1175, TDA2170, TDA2270, TDA8170, TDA8172, TDA8173, TDA8175 and TDA8176.

The equivalent circuit of the output stage is represented in Figure 34.

**Figure 34 :** Circuit utilized for the calculation of Midpoint and Gain for TDA1170, TDA1175, TDA8176, TDA2170, TDA2270, TDA8170, TDA8172, TDA8173 and TDA8175

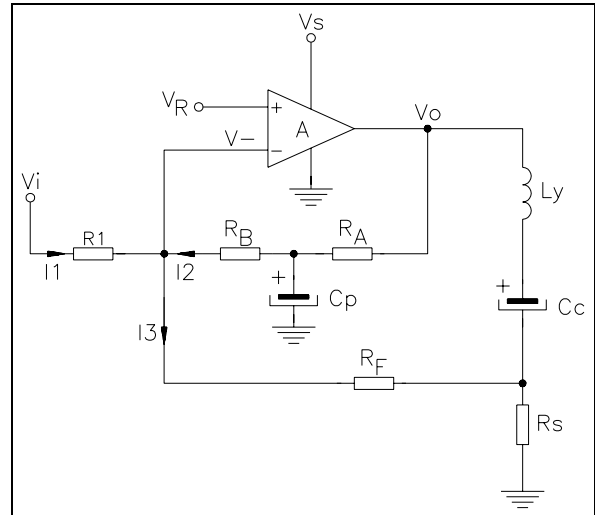

For DC considerations we shall consider the two capacitors as open circuits. Because of the very high gain of the amplifier we can suppose :

$$V^- = V_R.$$

We can so write :

$$I_1 + I_2 = I_3 \quad (30)$$

where :

$$I_1 = \frac{V_i - V_R}{R_1} \quad I_2 = \frac{V_O - V_R}{R_A + R_B} \quad I_3 = \frac{V_R}{R_F + R_S}$$

Substituting into the (30) we obtain :

$$V_O = V_R \left( 1 + \frac{R_A + R_B}{R_F + R_S} \right) - (V_i - V_R) \frac{(R_A + R_B)}{R_1} \quad (31)$$

## VERTICAL DEFLECTION CIRCUITS FOR TV & MONITOR

Let's consider now TDA1670A, TDA1675, TDA1770A, TDA1771, TDA1872A and TDA8174. The equivalent output circuit is depicted in Figure 35.

**Figure 35 :** Circuit utilized for the calculation of Midpoint and Gain for TDA1670A, TDA1675, TDA1770A, TDA1771, TDA1872A and TDA8174

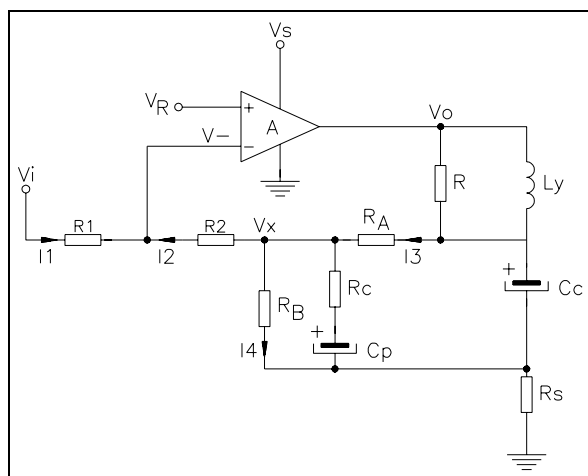

We can write :

$$I_1 = I_2 \quad (32)$$

$$I_2 + I_3 = I_4 \quad (33)$$

where :

$$I_1 = \frac{V_i - V_R}{R_1} \quad I_2 = \frac{V_R - V_X}{R_2} \quad I_3 = \frac{V_O - V_X}{R_A} \quad I_4 = \frac{V_X}{R_B + R_S}$$

with the (32) and (33) we can calculate the DC

output voltage. It results in :

$$V_O = V_R \left( 1 + \frac{R_A + R_2}{R_1} + \frac{R_A (R_1 + R_2)}{R_1 (R_B + R_S)} \right) - V_i \left( \frac{R_A + R_2}{R_1} + \frac{R_A \cdot R_2}{R_1 (R_B + R_S)} \right) \quad (34)$$

Referring to Figures 34 and 35, it is possible to calculate the transconductance gain of the power amplifier. For this calculation we shall do the following approximations :

- the capacitors are practically short circuits;
- the gain A of the amplifier is very high ( $A \rightarrow \infty$ ).

For the circuit represented in Figure 34 we obtain :

$$I_Y = \frac{R_F}{R_1 \cdot R_S} V_i \quad (36)$$

while for the application in Figure 35 the koke current results in :

$$I_Y = \frac{R_2 + R_A // R_B // R_C}{R_1 \cdot R_S} V_i \quad (37)$$

Using the (31), (34), (35) and (36) it is possible to calculate the external feedback network for every different yoke known the scanning current and the midpoint output voltage.

We can now consider the open loop gain of the whole system amplifier plus external feedback network. This calculation is useful in order to verify that no oscillations can occur at any frequency.

We shall consider some typical applications; the results are reported in Figures 36, 37 and 38.

It is easy to verify that in all cases, when the gain reaches 0dB, the phase margin is about  $60^\circ$ , so the stability of the system is assured.

Figure 36 : Open Loop Gain and Phase for the Application Circuit in Figure 27

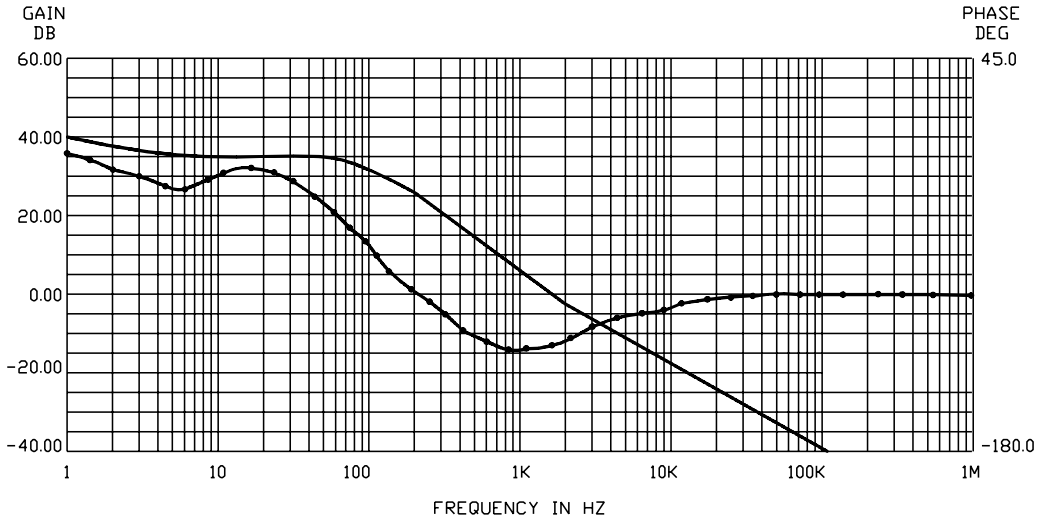

AN373-36.EPS

Figure 37 : Open Loop Gain and Phase for the Application Circuit in Figure 28

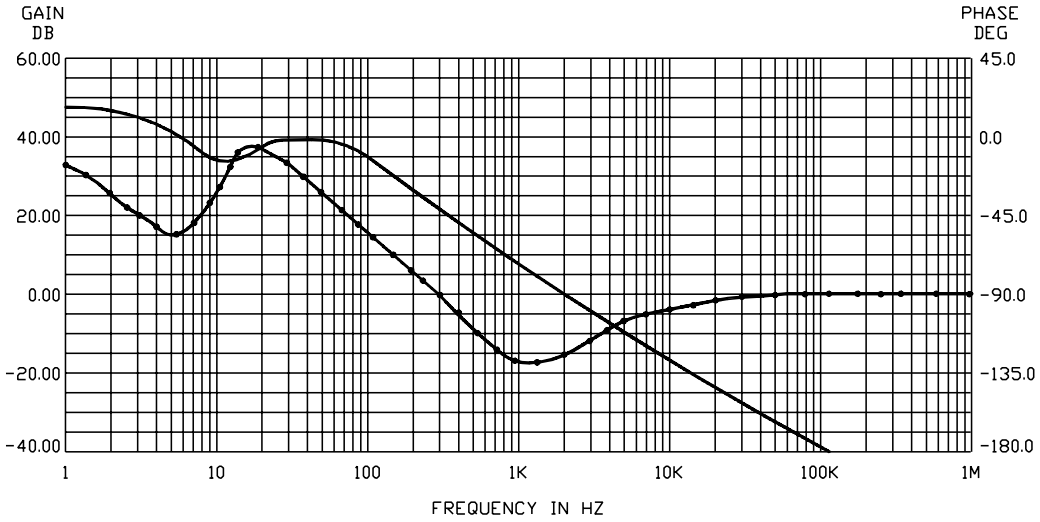

AN373-37.EPS

Figure 38 : Open Loop Gain and Phase for the Application Circuit in Figure 29

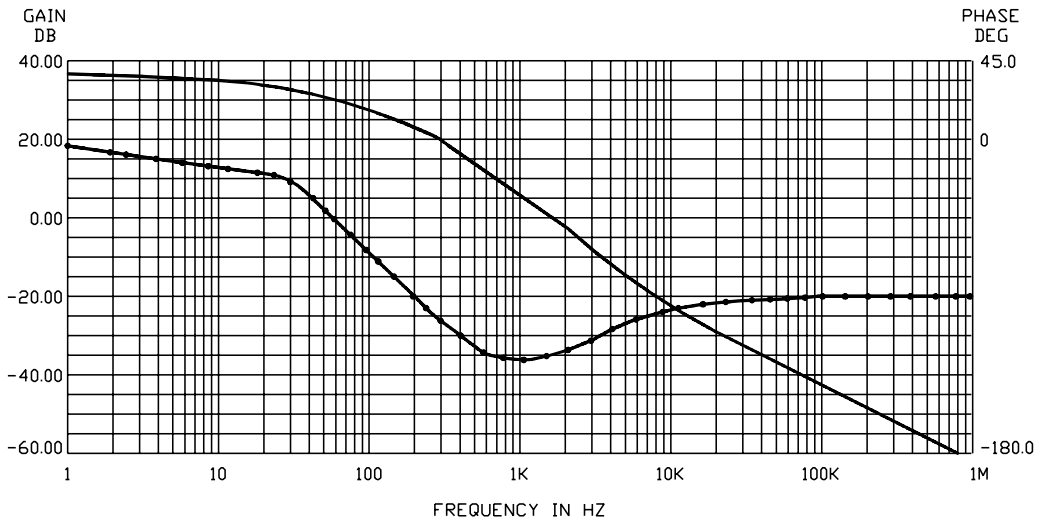

AN373-38.EPS

## VERTICAL DEFLECTION CIRCUITS FOR TV & MONITOR

### 13 - MONITOR APPLICATIONS

In monitor applications the flyback time needed could be very smaller than the one we get using the minimum supply voltage calculation.

It is possible to reduce the flyback time in two different ways :

- increasing the supply voltage, when the nominal value calculated is lower than the integrated circuit limit ;
- choosing a yoke with lower values in inductance and resistance and by supplying the circuit with the voltage needed for getting the right flyback time.

In both cases we have to calculate the biasing and the gain conditions using the nominal voltage and then we fix the supply voltage for the flyback time requested with the formula (18) :

$$V_S = \frac{2}{3} \frac{I_Y \cdot L_Y}{t_F}$$

The calculation procedure for monitors is so the same as the one we have explained in the previous chapters for television applications.

### 14 - POWER DISSIPATION

We shall now examine the power dissipation of the integrated circuit and the dimensions of the heatsink.

To calculate the power dissipated we must consider the maximum scanning current required to drive the yoke  $I_{Y(MAX)}$  and the maximum supply voltage  $V_{S(MAX)}$  because we have to dimension the heatsink for the worst case.

The current absorbed from the power supply is depicted in Figure 39.

**Figure 39 :** Current absorbed from the Power Supply during Scanning

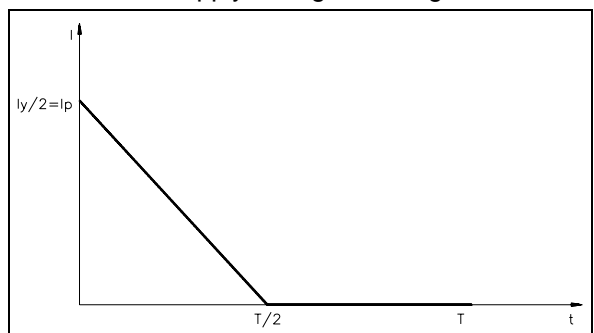

The equation of the curve :

$$\begin{aligned} i(t) &= \frac{I_Y}{2} - \frac{I_Y}{T} t && \text{for } 0 < t \leq T/2 \\ i(t) &= 0 && \text{for } T/2 < t \leq T \end{aligned} \quad (37)$$

To the previous one we have to sum the DC current necessary to supply the other parts of the circuit (quiescent current).

The power absorbed by the deflection circuit is then :

$$\begin{aligned} P_A &= \int_0^{T/2} V_{S(MAX)} \cdot i(t) \cdot dt + V_{S(MAX)} \cdot I_{DC} \\ &= V_{S(MAX)} \int_0^{T/2} \left( \frac{I_{Y(MAX)}}{2} - \frac{I_{Y(MAX)}}{T} t \right) dt + V_{S(MAX)} \cdot I_{DC} \end{aligned}$$

The solution is :

$$P_A = V_{S(MAX)} \left( \frac{I_{Y(MAX)}}{3} + I_{DC} \right) \quad (38)$$

The power dissipated outside the integrated circuit is formed by the three following fundamental components : the scanning power dissipated in the yoke for which the minimum resistance of yoke  $R_{Y(MIN)}$  and the maximum scanning current  $I_{Y(MAX)}$  must be considered, the power dissipated in the feedback resistance  $R_F$  and that one dissipated in the diode for recovery of flyback.

The power dissipated outside the integrated circuit is then :

$$\begin{aligned} P_Y &= \int_0^T (R_{Y(MIN)} + R_F) i^2(t) \cdot dt + \int_0^{T/2} V_{D_D} i(t) \cdot dt \\ &= (R_{Y(MIN)} + R_F) \int_0^T \left( \frac{I_{Y(MAX)}}{2} - \frac{I_{Y(MAX)}}{T} t \right)^2 dt \\ &\quad + V_D \int_0^{T/2} \left( \frac{I_{Y(MAX)}}{2} - \frac{I_{Y(MAX)}}{T} t \right) dt \end{aligned}$$

The solution is :

$$P_Y = \frac{I_{Y(MAX)}^2 (R_{Y(MIN)} + R_F)}{12} + \frac{I_{Y(MAX)} \cdot V_D}{8} \quad (39)$$

The Power dissipated inside the integrated circuit is :

$$P_D = P_A - P_Y \quad (40)$$

The thermal resistance of the heatsink to be used with the integrated circuit depends upon the maximum junction temperature  $T_{J(MAX)}$ , the maximum ambient temperature  $T_{amb}$  and the thermal resistance between junction and tab  $R_{th(j-TAB)}$  that is different for the various packages used. The thermal resistance of the heatsink is expressed by the following formula :

$$R_{th(j-a)} = \frac{T_{J(MAX)} - T_{amb(MAX)}}{P_{D(MAX)}} - R_{th(j-TAB)} \quad (41)$$

As an example we can calculate the dissipated power and the thermal resistance of the heatsink for the 26", 110°, neck 29.1mm tube for which we calculated the minimum supply voltage in chapter 11.

We shall consider the integrated circuit TDA1670A and we can suppose a maximum supply voltage of 25V.

The power absorbed from the supply is :

$$P_A = 25 \left( \frac{1.2}{8} + 0.04 \right) = 4.75W$$

The power dissipated outside the integrated circuit is :

$$P_Y = \frac{1.2^2 (9.6 \cdot 0.93 + 1.2)}{12} + \frac{1.21}{8} = 1.37W$$

therefore the power dissipated by the integrated circuit is :

$$P_D = 4.75 - 1.37 = 3.38W$$

The thermal resistance of the heatsink, considering the  $R_{th(j-TAB)}$  for the multiwatt package of 3°C/W, a maximum junction temperature of 120°C and a maximum ambient temperature of 60°C is :

$$R_{th(j-a)} = \frac{120 - 60}{3.38} - 3 = 15^\circ C/W$$

For the same application with TDA1170S we have a thermal resistance for the heatsink of about 8°C/W.

### 15 - BLANKING PULSE DURATION ADJUSTMENT

For the devices that have the blanking generator it is possible to adjust the blanking pulse duration.

We shall consider as an example the TDA1670A; the circuit arrangement is depicted in Figure 40.

**Figure 40 :** Circuit Arrangement for Blanking Pulse Duration Adjustment

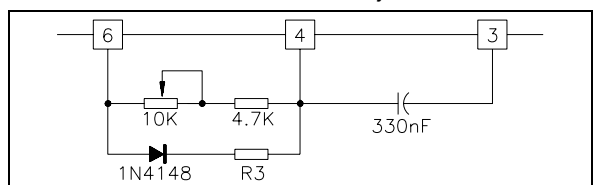

By adjusting  $R_3$  the blanking pulse duration will be adapted to the flyback time used and the picture tube protection will be ready to work properly. When necessary, it is possible to use a trimmer system to adjust it very carefully.

### 16 - LINEARITY ADJUSTMENT

The complete vertical stages have the possibility to control the linearity of the vertical deflection ramp. There are two different methods to obtain the above mentioned performance.

**a) For the first method we shall refer to Figure 41**

The linearity regulation is obtained by means of  $R_A$ ,  $R_B$  and  $R_{T2}$ .

**Figure 41 :** Circuitry for Ramp Linearity Regulation

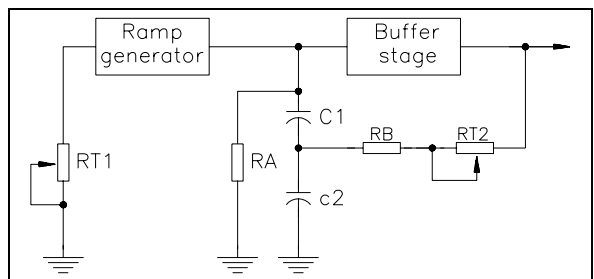

In order to choose the right values of this components we suggest to follow the following procedure :

- 1 - Set the amplitude regulation potentiometer  $R_{T1}$  for the nominal raster size ;
- 2 - Disconnect the  $R_A$  resistance ;
- 3 - Adjust the linearity control potentiometer  $R_{T2}$  in order to obtain the top and the bottom of the raster with the same amplitude ;
- 4 - In this condition the center of the raster must be narrower than the top and the bottom. If with  $R_A$  disconnected the center is larger than the top and the bottom it is necessary to act on the feedback network. Referring to Figures 27, 28 and 29 it is necessary to increase the capacitors  $C_{11}$ ,  $C_8$  or  $C_6$  ;

## VERTICAL DEFLECTION CIRCUITS FOR TV & MONITOR

- 5 - After increasing the capacitors it is necessary to repeat the linearity adjustment ( $R_{12}$  potentiometer) in order to get the top and the bottom with the same amplitude again ;
- 6 - Connect the  $R_A$  resistor and repeat the linearity adjustment (point 3 regulation) ;
- 7 - Check the top and the bottom amplitude comparing it with the center. If the center amplitude is still narrower it is necessary to reduce  $R_A$ . If the center amplitude becomes larger it is necessary to increase  $R_A$ .

Note : Every time the linearity conditions are changed (for adjusting or setting) before checking the linearity status, the point 3 adjustment must be repeated.

### b) For the second method we shall refer to Figure 28

In this case the linearity regulation is obtained acting directly on the feedback network, that is substituting the  $R_8$  resistance with a potentiometer. This solution is cheaper than the first one, because it is possible to save the resistors  $R_A$ ,  $R_B$  (see Figure 41), the potentiometer  $R_{T2}$  and to use only a capacitor instead of the series  $C_1$  and  $C_2$ .

On the other hand a disadvantage is due to the fact that the resistance  $R_8$  influences not only the linearity of the ramp but also the gain of the amplifier, as it can be seen in the equation (36). So to perform a linearity adjustment it is necessary to act at the same time on the potentiometer in the feedback loop and on the potentiometer  $R_{T1}$  (see Figure 41) in order to correct the vertical amplitude variations. On the contrary, in the method a) the linearity control network doesn't influence any other parameters. this is the reason why the a) method is generally adopted by all television set producers.

## 17 - FACILITIES AND IMPROVEMENTS

In this section we shall briefly examine some facilities which may be useful to improve operations of the television set.

### a) Blanking generator and CRT protection for TDA1170 family

At pin 3 a pulse is available which has the same duration and phase as the flyback and amplitude equal to the supply voltage.

If the retrace duration is not sufficient for carrying

out correct vertical blanking, for instance in the presence of text and teletext signals the circuit of Figure 42 can be used.

**Figure 42 :** Blanking Generator and CRT Protection for TDA1170

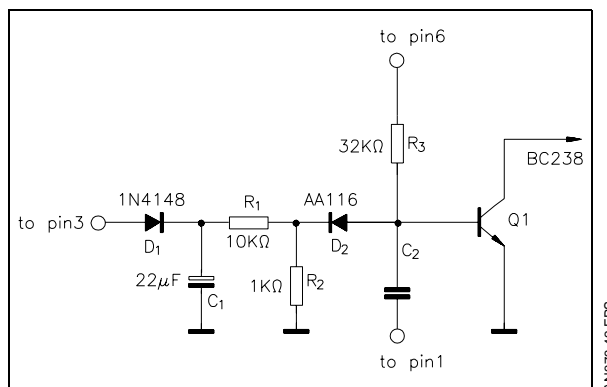

The true blanking generator is formed by  $Q_1$ ,  $R_3$  and  $C_2$  and the blanking duration is dependent upon the values of  $R_3$  and  $C_2$ . The other components are used for picture tube protection in the event of loss of vertical deflection current. If for any reason there is no flyback, the transistor  $Q_1$  is permanently inhibited and provides continuous switch off which eliminates the white line at the center of the screen. Thermal stability and stability with the supply voltage is good in relation to the simplicity of the application.

### b) Vertical deflection current compensation to maintain picture size with beam current variations

Changes in the supply voltage or the brightness and contrast controls will bring out changes of the beam current, thus causing EHT and picture size variations.

The rate of change of the picture size is mainly dependent upon the EHT internal resistance.

In order to avoid variations of the vertical picture size it is necessary to track the scanning current to the beam current. Because the tracking ratio :

$$\frac{\Delta I_{YOKE}}{\Delta I_{BEAM}} \cdot 100 \quad (42)$$

varies from one chassis design to another, three suggested tracking circuits are shown in Figures 43, 44 and 45.

The circuit in Figure 43 adopts the straight forward technique of linking the vertical scanning current directly to the beam current. Its drawback lies in the fact that a long wire connection is required between the EHT transformer and the vertical circuit, and the layout of this connection could be critical for flashover.

**Figure 43 :** Circuit for Vertical Scanning Current Variation according with the Beam Current

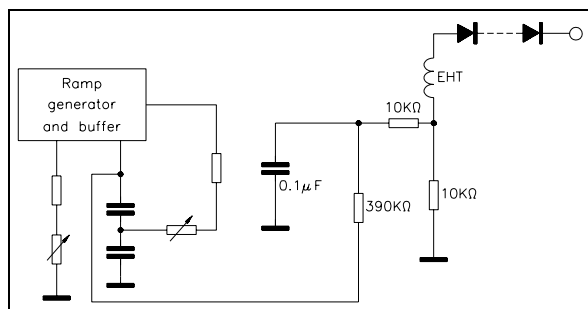

The circuit of Figure 44, which links the vertical scanning current directly to the supply voltage, is the simplest one. Its drawback could be incorrect tracking ratio and ripple on the supply voltage. To overcome the drawbacks of the preceding circuit it is useful to filter out the supply voltage ripple and adjust the tracking ratio by transferring the supply voltage to a lower level by means of a Zener diode as shown in Figure 45. Tracking ratio is adjusted by choosing a suitable Zener voltage value.

**Figure 44 :** Circuit for Vertical Scanning Current Variation according with the Supply Voltage

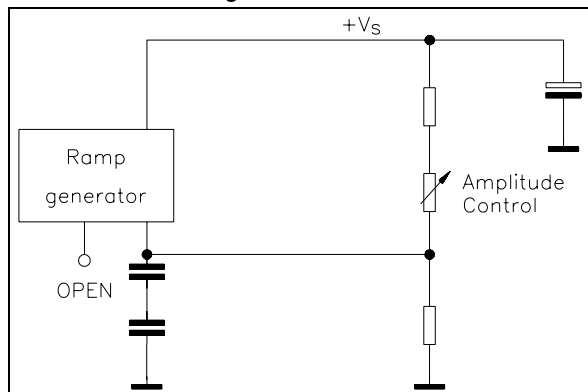

**Figure 45 :** Circuit for Vertical Scanning Current Variation according with the Supply Voltage

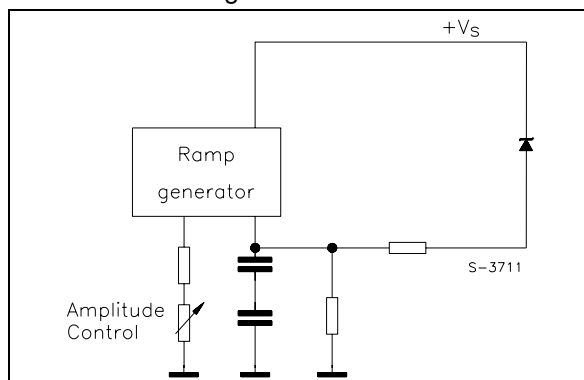

### 18 - GENERAL APPLICATION AND LAYOUT HINTS

In order to avoid possible oscillations induced by the layout it is very important to do a good choice of the Boucherot cell position and ground placing. The Boucherot cell must be placed the most possible closed to the vertical deflection output of the integrated circuit, while the ground of the sensing resistor in series connected with the yoke must be the same as the one of the integrated circuit and different from the one of other power stages. Particular care must be taken in the layout design in order to protect the integrated circuit against flashover of the CRT. For instance the ground of the filter capacitor connected to the power supply must be near the integrated circuit ground.

### 19 - REFERENCES

- 1) Television Deflection Systems - A. Boekhorst, J. Stolk - Philips Technical library.
- 2) TV Vertical Deflection System TDA1170S - SGS-THOMSON Application Notes.
- 3) TDA1670A Technical Note - SGS-THOMSON Technical Note.
- 4) TV and Monitor Vertical Deflection using TDA1670A - O. Cossutta, F. Gatti SGS-THOMSON Application Notes.
- 5) TDA1670A Flyback Stage Behaviour - A. Messi, G. Nardini - SGS-THOMSON Application Notes.

Information furnished is believed to be accurate and reliable. However, SGS-THOMSON Microelectronics assumes no responsibility for the consequences of use of such information nor for any infringement of patents or other rights of third parties which may result from its use. No licence is granted by implication or otherwise under any patent or patent rights of SGS-THOMSON Microelectronics. Specifications mentioned in this publication are subject to change without notice. This publication supersedes and replaces all information previously supplied. SGS-THOMSON Microelectronics products are not authorized for use as critical components in life support devices or systems without express written approval of SGS-THOMSON Microelectronics.

© 1994 SGS-THOMSON Microelectronics - All Rights Reserved

Purchase of I<sup>2</sup>C Components of SGS-THOMSON Microelectronics, conveys a license under the Philips I<sup>2</sup>C Patent. Rights to use these components in a I<sup>2</sup>C system, is granted provided that the system conforms to the I<sup>2</sup>C Standard Specifications as defined by Philips.

**SGS-THOMSON Microelectronics GROUP OF COMPANIES**

Australia - Brazil - China - France - Germany - Hong Kong - Italy - Japan - Korea - Malaysia - Malta - Morocco  
The Netherlands - Singapore - Spain - Sweden - Switzerland - Taiwan - Thailand - United Kingdom - U.S.A.

ORDER CODE :