

Laboratory Session 4 – The 7-Segment LED

Name _____ Name _____ Name _____

Materials:

7-segment LED
BCD to 7-segment decoder (7447 chip)
7 470 Ω resistors
4 switches

Protoboard
Wires
Wire Stripper

Introduction:

There's a huge language barrier that separates humans from computers. Sure some people, like students like yourself, can go in and measure voltages and certain points to see what's going on, but to most people this isn't possible. How can computers communicate with people? A popular form of communication is the 7-segment LED. You've seen them on stereos, VCR's, clocks, everywhere. This visual display communicates information from the computer to a person, transforming 1's and 0's into decimal numbers.

In this lab we will build a tool to convert binary numbers into visible digits using a 7447 BCD decoder chip. This chip simply converts a binary input into a form the 7-segment can interpret.

7-segment LED

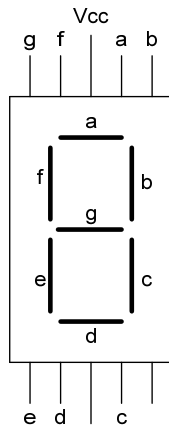

7447 BCD Decoder

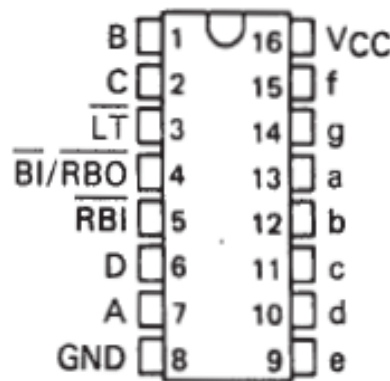

1. Connect A, B, C, and D of the 7447 chip to the switches on the board. A switch simply alternates between HI and LO when it is flipped. Leave LT, BI/RBO, and RBI unconnected.
2. The outputs of the chip will go into the 7-segment display. Note that you will need resistors before connecting 7447 Decoder to the 7-segment LED in order to reduce the voltage running through the LED.

Use the chip information above to help you build your circuit. Make sure all chips that are in use have V^+ and ground connected. If you need help, the full schematic is shown on the next page.

3. Now you should be able to make a binary pattern out of the four switches on the board and see the decimal digit displayed on the 7-segment display. Test all of the ten numerical digits to make sure everything is working properly.

Binary to Decimal/7-Segment LED Circuit Schematic

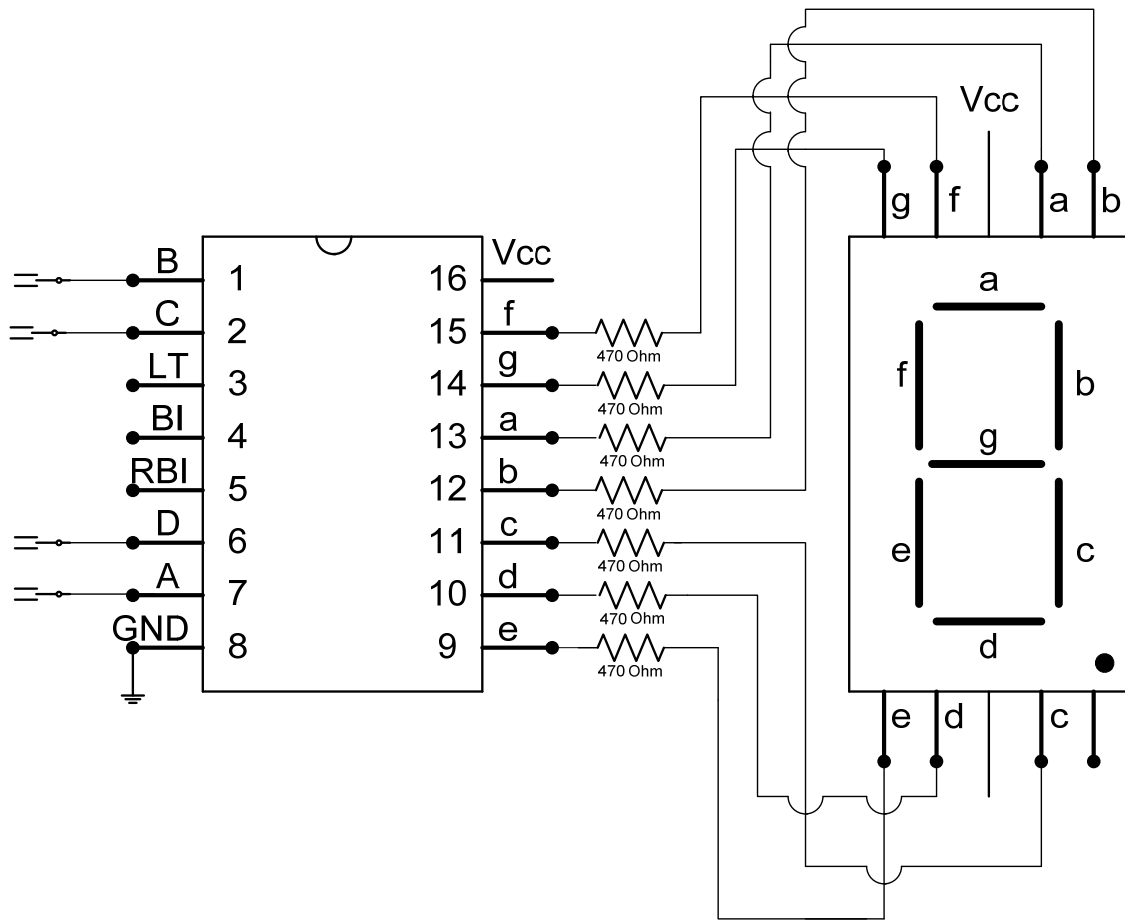

Truth table of 7447 decoder chip :

Input				Output							
D	C	B	A	a	b	c	d	e	f	g	Digit
L	L	L	L	L	L	L	L	L	L	L	0
L	L	L	H	H	L	L	H	H	H	H	1
L	L	H	L	L	L	H	L	L	H	L	2
L	L	H	H	L	L	L	L	H	H	L	3
L	H	L	L	H	L	L	H	H	L	L	4
L	H	L	H	L	H	L	L	H	L	L	5
L	H	H	L	H	H	L	L	L	L	L	6
L	H	H	H	L	L	L	H	H	H	H	7
H	L	L	L	L	L	L	L	L	L	L	8
H	L	L	H	L	L	L	H	H	L	L	9