

## Three-Phase Induction Motor

### **EXPERIMENT Induction motor**

#### **Three-Phase Induction Motors**

#### **OBJECTIVE**

This experiment demonstrates the performance of squirrel-cage induction motors and the method for deriving electrical equivalent circuits from test data.

#### **REFERENCES**

1. “Electric Machinery”, Fitzgerald, Kingsley, and Umans, McGraw-Hill Book Company, 1983, Chapter 9.
2. “Electric Machinery and Transformers”, Kosow, Irving L., Prentice-Hall, Inc., 1972.
3. “Electromechanical Energy Conversion”, Brown, David, and Hamilton, E. P., MacMillan Publishing Company, 1984.
4. “Electromechanics and Electric Machines”, Nasar, S. A., and Unnewehr, L. E., John Wiley and Sons, 1979.

#### **BACKGROUND INFORMATION**

The three-phase squirrel-cage induction motor can, and many times does, have the same armature (stator) winding as the three-phase synchronous motor. As in the synchronous motor, applying three-phase currents to the armature creates a synchronously-rotating magnetic field.

The induction motor rotor is a completely short-circuited conductive cage. Figures 1 and 2 illustrate the rotor construction.

# Three-Phase Induction Motor

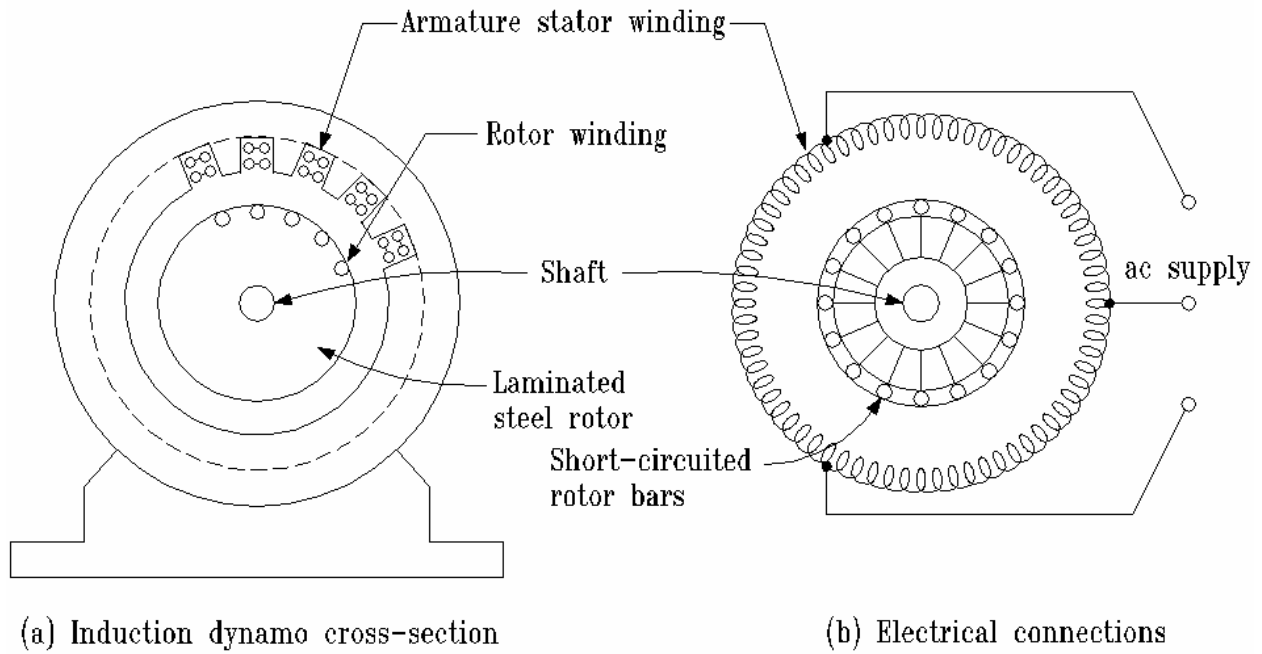

**Figure 1: Induction machine construction.**

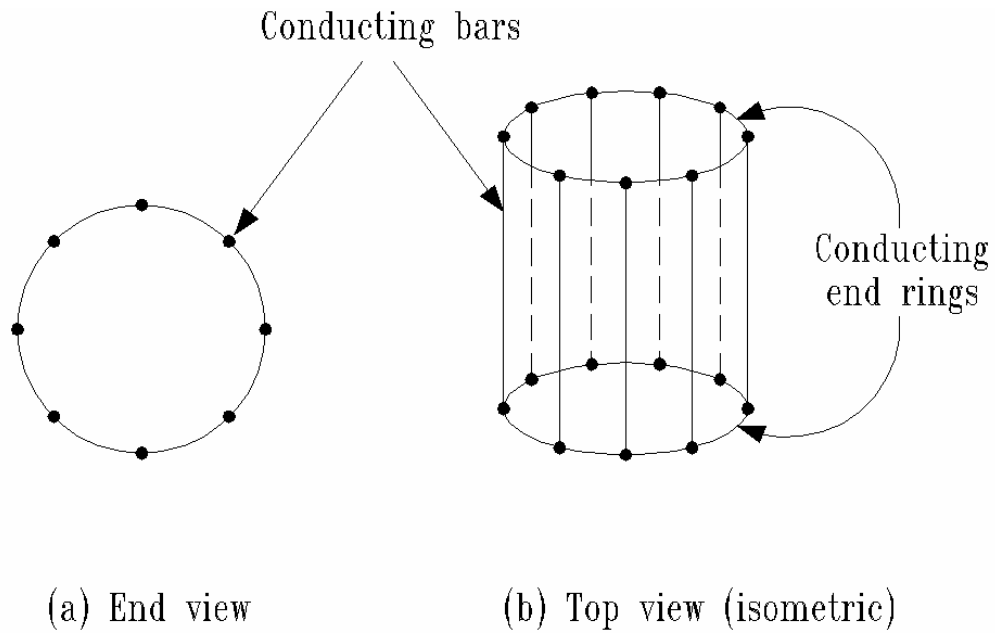

**Figure 2: Squirrel-case rotor.**

## Three-Phase Induction Motor

The rotor receives its excitation by induction from the armature field. Hence, the induction machine is a doubly-excited machine in the same sense as the synchronous and DC machines.

The basic principle of operation is described by Faraday's Law. If we assume that the machine rotor is at a standstill and the armature is excited, then the armature-produced rotating field is moving with respect to the rotor. In fact, the relative speed between the rotating field and the rotor is synchronous speed. For this condition, the rotating field induces a large voltage in the rotor bars. The large voltage causes a large current in the squirrel-cage which, in turn, creates a magnetic field in the rotor. The rotor magnetic field interacts with the armature magnetic field, and a torque is produced. If the produced torque is larger than any load torque, the rotor begins to turn. As the rotor accelerates, the speed difference between the rotor and the armature field is reduced. This reduced speed difference (or slip) causes the induced rotor voltage to be reduced, the rotor current to be reduced, the rotor flux to be reduced, and the torque produced by the machine to be reduced. Eventually, the torque produced by the motor equals the torque demanded by the load, and the motor settles to an equilibrium rotor speed. This equilibrium rotor speed must be less than synchronous speed since there must be a slip to produce torque.

The frequency-dependent nature of the rotor impedances causes the torque versus speed characteristic of the induction motor to be quite non-linear. Figure 3 shows a typical characteristic.

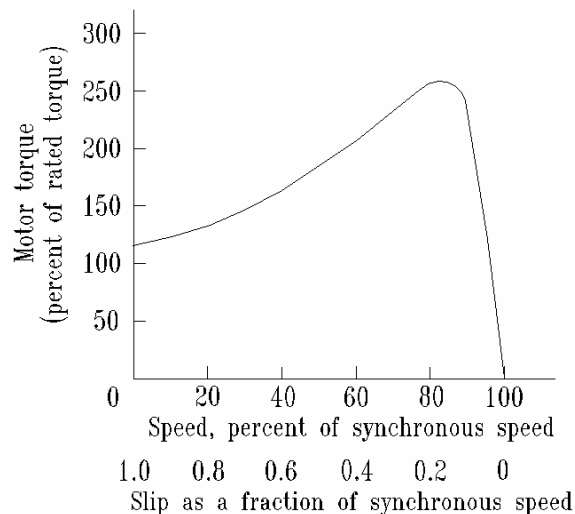

**Figure 3:** Typical induction motor torque-speed curve.

## Three-Phase Induction Motor

Designers have learned to design rotors for specific torque characteristics. The National Electrical Manufacturers Association NEMA has classified and standard designs which satisfy a range of torque-speed characteristics. Figure 4 shows the NEMA designs and the rotor bar geometries that produce the responses.

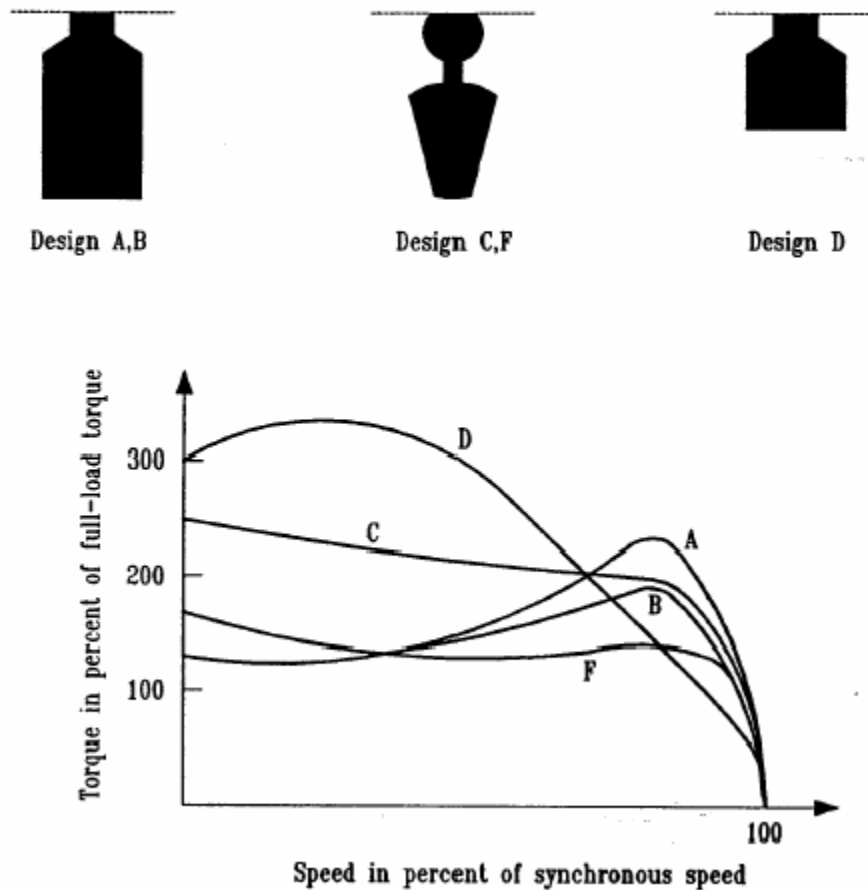

**Figure 4:** Effects of rotor bar geometry on torque characteristics in squirrel-case machines.

## Three-Phase Induction Motor

The induction motor is normally modeled as an equivalent electrical circuit. Figure 5 shows typical equivalent circuits.

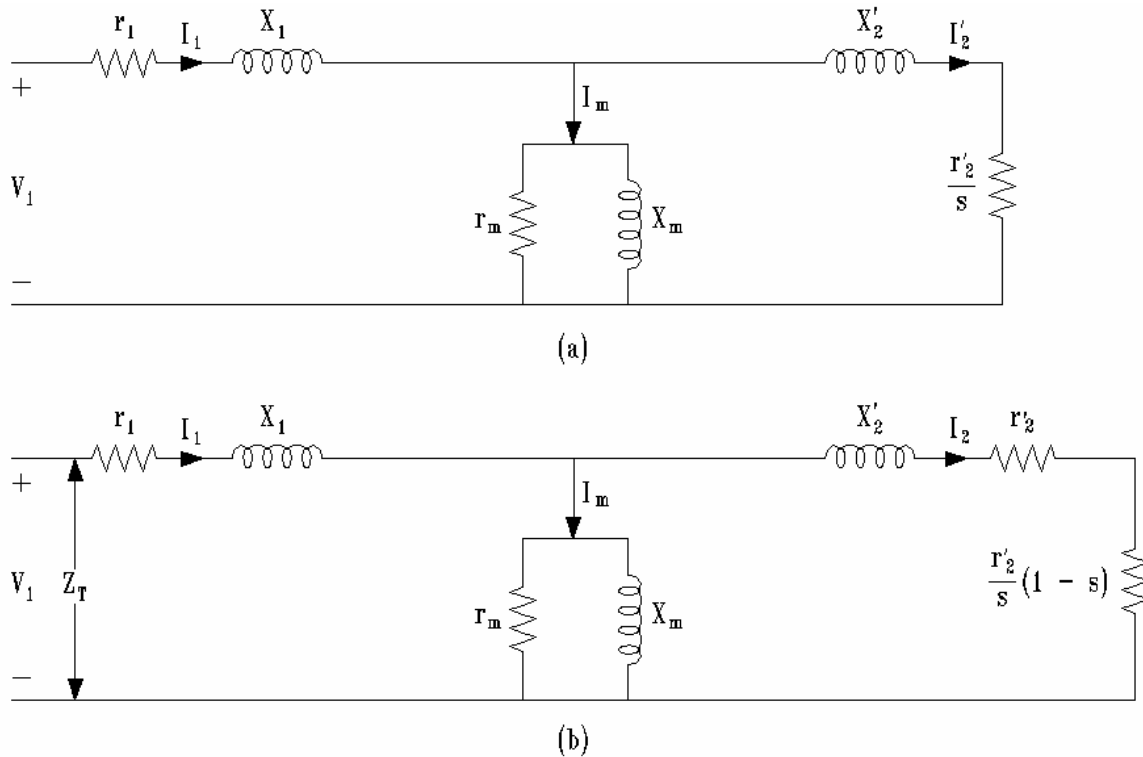

**Figure 5:** Two forms of equivalent circuits of an induction motor.

**Remember**  $SLIP = (SPEED_{syn} - SPEED_m) / SPEED_{syn}$

$$P = T \omega$$

$$Q = \sqrt{S^2 - P^2}$$

$$P_{dev} = I_2^2 \frac{r_2'}{slip} (1 - slip) \text{ for one phase}$$

$$T = P/\omega$$

$$R_{sc} = P_{sc} / I_{sc}^2$$

$$X_{sc} = Q_{sc} / I_{sc}^2$$

$$R_1 = 2.3\Omega$$

$$R_2 = R_{sc} - R_1$$

$$X_1 = X_2 = X_{sc} / 2$$

$$pf = P/S$$

$$Z_1 = R_1 + j X_1$$

## Three-Phase Induction Motor

$$V_{\text{core}} = V_{\text{oc}} - (I_{\text{oc}})(Z_1)$$

$$P_{\text{core}} = P_{\text{oc}} - R_1(I_{\text{oc}}^2)$$

$$Q_{\text{core}} = Q_{\text{oc}} - X_1(I_{\text{oc}}^2)$$

$$R_c = (V_{\text{core}})^2 / P_{\text{core}}$$

$$X_m = (V_{\text{core}})^2 / Q_{\text{core}}$$

The impedances of the circuits shown in Figure 5 are found from no-load and blocked-rotor tests. Full descriptions of the circuits and the tests are found in Reference 1.

The torque-speed characteristic of an induction motor can be significantly changed by designing different resistance values within the rotor bars. Figure 6 shows the impact of different rotor resistance values.

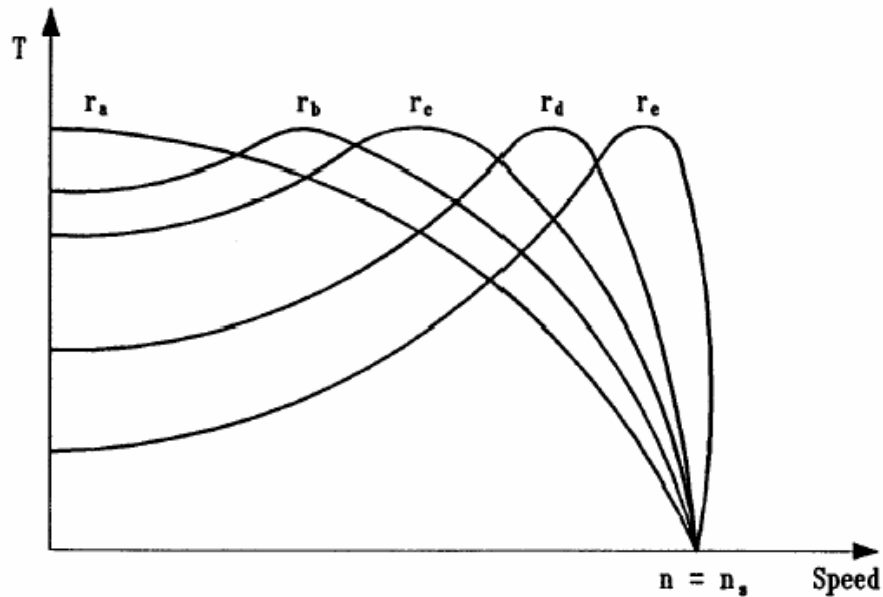

## Three-Phase Induction Motor

**Figure 6:** Effect of changing rotor resistance on the torque-speed characteristic of an induction motor.

### INTRODUCTION

The squirrel-cage induction motor is already mounted to the dynamometer. Note that the pulley system ratio is 1:1. Therefore, the motor being tested operates at same the speed of dynamometer. The motor is rated for  $\frac{1}{4}$  horsepower,  $115V_{L-L}$ , and 1725 RPM. Its rated full-load current is 2.5 amperes. The stator resistance was measured by an ohmmeter and is  $2.3\Omega/\text{phase}$ . This is the  $R_I$  value to be used for the equivalent circuit. Note that  $R_I$  cannot be neglected for the no-load tests.

The neutral of the motor is not accessible; however, since the motor is balanced, its effective neutral will be very close to the power supply neutral.

We cannot run a test to measure the actual starting torque at rated voltage. The current is very high and quickly burns the motor.

### SUGGESTED PROCEDURE

1. Connect the system shown in Figure 7. Note that the measured voltages are line-to-line values, measured currents are phase currents, and measured power is for one phase only.

Run the no-load test at rated voltage ( $115V_{L-L}$ ). Record  $I$ ,  $V_{L-L}$ ,  $P_1 - \phi$ .

$V_{L-L}$ Rated	$V_{L-N}$ Calculated	$I_{\text{Line}}$	$P_{\text{in phase}}$
$115V_{L-L}$			

Secure the motor with the clamp. Run the blocked-rotor test at rated line current (2.5A).

Record  $I$ ,  $V_{L-L}$ ,  $P_1 - \phi$ .

$V_{L-L}$	$V_{L-N}$ Calculated	$I_{\text{Line}}$	$P_{\text{in phase}}$
		2.5A	

### Three-Phase Induction Motor

2. Remove the rotor lock from the dynamometer and apply rated voltage to the induction motor. Place all five switches on the load bank in the “up” position. Adjust the dynamometer field to load the induction motor to rated current (2.5A). Measure the torque and speed.

<b>V<sub>L-L</sub> Rated</b>	<b>I<sub>Line</sub> Rated</b>	<b>P<sub>in</sub> phase</b>	<b>RPM</b>	<b>Torque</b>	<b>V<sub>Dyn</sub></b>	<b>I<sub>Dyn</sub></b>
<b>115V</b>	<b>2.5A</b>					

3. For the following test, do not let the machine run above rated current for sustained periods of time.
- a) Using 100% of rated voltage (115V<sub>L-L</sub>), maintain constant, take the measurements shown to complete the table below, as motor armature current is varied from rated current (2.5A) to 3.0 Amps. Control the induction motor line current by adjusting the dynamometer field.

<b>V<sub>mot</sub> L-L</b>	<b>I<sub>mot</sub></b>	<b>RPM</b>	<b>Torque</b>	<b>V<sub>d</sub></b>	<b>I<sub>d</sub></b>
115 V	2.5 A				
115 V	2.6 A				
115 V	2.7 A				
115 V	2.8 A				
115 V	2.9 A				
115 V	3.0 A				
<b>100 % Voltage Line-to-Line</b>					

- b) Repeat part “a” using 90% of rated voltage. Complete the table below..

<b>V<sub>mot</sub> L-L</b>	<b>I<sub>mot</sub></b>	<b>RPM</b>	<b>Torque</b>	<b>V<sub>d</sub></b>	<b>I<sub>d</sub></b>
103 V	2.5 A				
103 V	2.6 A				
103 V	2.7 A				
103 V	2.8 A				
103 V	2.9 A				
103 V	3.0 A				

## Three-Phase Induction Motor

<b>90 % Voltage Line-to-Line</b>
----------------------------------

- c) Repeat part “a” using 80% of rated voltage. Complete the table below.

<b>V<sub>mot</sub> L-L</b>	<b>I<sub>mot</sub></b>	<b>RPM</b>	<b>Torque</b>	<b>V<sub>d</sub></b>	<b>I<sub>d</sub></b>
92 V	2.5 A				
92 V	2.6 A				
92 V	2.7 A				
92 V	2.8 A				
92 V	2.9 A				
92 V	3.0 A				
<b>80 % Voltage Line-to-Line</b>					

Install the dynamometer lock for the next class.

### **REPORT**

1. Derive an equivalent circuit like Figure 5 for the tested machine. Assume a NEMA “D” motor.  $X_1 = X_2'$  in the equivalent circuit.
2. Plot the torque vs. speed and current vs. speed from the experiment data. **Note:** Plot the three different voltage cases for torque on the same plot. Plot the three different voltage cases for current on the same plot.
3. Using the equivalent circuit, plot torque vs. speed curves and current vs. speed for 80%, 90% and 100% of rated voltage as speed varies from 1 to 1800 RPM. **Note:** Plot the three different voltage cases for torque on the same plot. Plot the three different voltage cases for current on the same plot. Compare the calculated data with the measured data include MATLAB program listing and plot output.

## Three-Phase Induction Motor

4. Increase the resistor in the rotor by  $1\Omega$ , of the equivalent circuit and recalculate the curves as above. This new set of curves is equivalent to adding resistance to the rotor of the machine. **Note:** Plot the three different voltage cases for torque on the same plot. Plot the three different voltage cases for current on the same plot.
5. Comment on the differences noted between using stator voltage control and adding rotor resistance, to control the speed of the motor.
6. Explain why the induction motor slows down as the load is increased.
7. Explain how the three-phase induction motor develops starting torque.

## Three-Phase Induction Motor

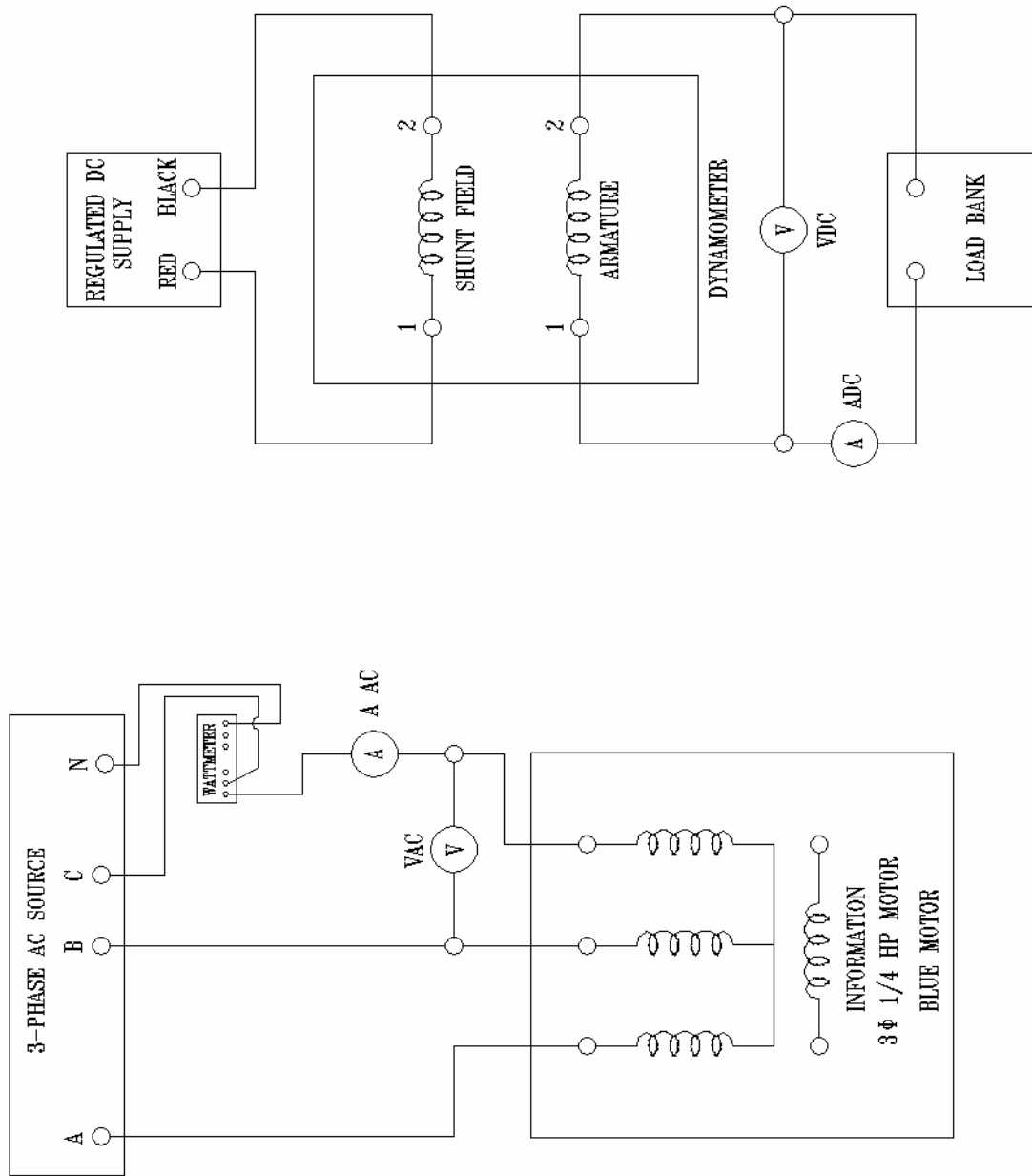

**FIGURE 7: INDUCTION MOTOR TEST CONNECTION**